

# A singularly perturbed Delay Differential Equation modeling nosocomial infections

A. DUCROT, P. MAGAL, O. SEYDI

*Institut de Mathematiques de Bordeaux, UMR CNRS 5251,  
Universite Bordeaux Segalen, 3ter place de la Victoire, 33000 Bordeaux, France*

## Abstract

In this article we consider a model describing hospital acquired infections. The model derived is a system of delay differential equations. The state variable is formed by the patients and the healthcare workers components. The system is a slow-fast system where the fast equation corresponds to the healthcare workers equation. The question addressed in this paper is the convergence to the so called reduced equations which is a single equation for patients. We investigate both finite time convergence and infinite time convergence (uniformly for of all positive time) of the original system to the reduced equation.

## 1 Introduction

In this article, we consider a model describing bacterial nosocomial infections (i.e. hospital acquired infections). In such a problem the pathogens (bacteria) are assumed to be transmitted from the patients to the HealthCare Workers (HCW) and from the HCWs to the patients. A Susceptible ( $S$ ) patient may become newly Infected ( $I$ ) patient by contact with a colonized HCW. Typically, the colonization of HCWs is of a superficial form such as dirty hands that carry the pathogen. The HCWs are decomposed into the Uncolonized ( $H_U$ ) and the Colonized ( $H_C$ ). The fluxes of patients and HCWs are summarized in Figure 1.

The time scales for the process of colonization for HCWs and the process of infection for patients are fairly different. HCWs may recover from the colonization due to hygiene or due to the turn over in the medical unit (i.e. a shifts of 8 Hours). When a HCW becomes colonized, the HCW is assumed to be immediately capable to transmit the pathogen to a patient. The average time during which the HCW stays colonized is approximatively one or two hours. For a patient the infection process is much longer, and a patient needs several days to be capable to transmit the pathogen to HCWs. Therefore when a patient become infected, the period of time necessary to transmit the pathogen from

patients to an HCW is much longer. In this sense there is (at least) one order of magnitude between the time scale for HCWs and the time scale for patients.

In this article, we will consider a special version of a model presented in Magal and McCluskey [20, Section 7]. By using the usual idea coming from slow-fast systems, we will cancel out the HCWs component of the system. Similar idea was already used in D'Agata et al. [11] (without mathematical justification), and as [11] we will end up with a single equation for patients. The model derived turn to be similar (but different) to the one introduced in Webb et al. in [26]. A practical motivation for this study come from the fact that (usually) no data are available for the colonized HCWs. Therefore it also makes sense to try to get rid of the HCWs component in such a problems.

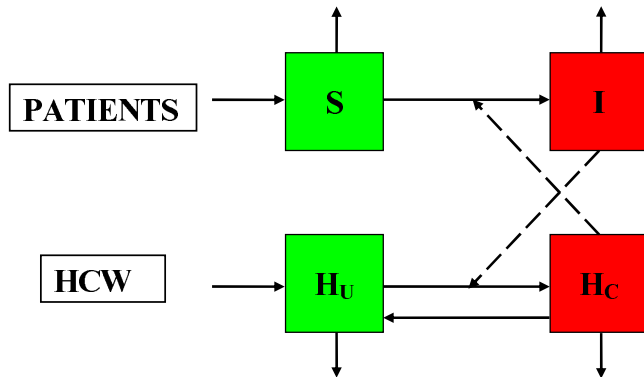

Figure 1: *The figure represents a diagram of the individuals fluxes used to describe hospital acquired infections. In this diagram each solid arrow represents a flux of individuals, while the dashed arrows represent the influence of either infected patients or colonized HCWs on the pathogen acquisition.*

Let  $S(t)$  be the number of susceptible patients at time  $t$ , and  $i(t, a)$  be the density of infected patients who have been infected for duration  $a$  at time  $t$ . This means that

$$\int_{a_-}^{a_+} i(t, a) da$$

is the number of infected patients having an age of infection (i.e. the time since infection)  $0 \leq a_- \leq a \leq a_+$ . The age of infection is introduced in such a context to account for antibiotic treatment in the model. Let  $H_U(t)$  be the number of uncolonized HCWs,  $H_C(t)$  be the number of colonized HCWs. Assume that the number of patients and HCWs is constant in the hospital (or the intensive care unit), therefore we must have

$$S(t) + \int_0^{+\infty} i(t, a) da = N_P \quad \text{and} \quad H_U(t) + H_C(t) = N_H. \quad (1.1)$$

$$\text{Patient equation} \left\{ \begin{array}{l} \frac{dS(t)}{dt} = \nu_R N_P - \nu_R S(t) - \frac{\nu_V P_I}{N_H} \beta_V S(t) H_C(t) \\ \frac{\partial i(t, a)}{\partial t} + \frac{\partial i(t, a)}{\partial a} = -\nu_R i(t, a), \\ i(t, 0) = \frac{\nu_V P_I}{N_H} \beta_V S(t) H_C(t) \\ S(0) = S_0 \geq 0 \\ i(0, \cdot) = i_0 \in L^1_+(0, +\infty), \end{array} \right. \quad (1.2)$$

The rate  $\nu_V$  at which contacts between staff and patients occur is taken to be constant. The probability for a patient to have contact with a HCW is  $\beta_V := N_H/N_p$  and when a contact occurs the probability that is with a contaminated HCW is the fraction  $\frac{H_C}{N_H}$  of HCWs that are colonized, where  $N_H$  is the total number of HCWs and  $N_p$  is the total number of patients. Finally, given a contact between a susceptible patient and a contaminated HCW, the probability that the patient becomes infected is  $P_I \in (0, 1]$ . Thus, the rate at which incidence of new infections in the patient population is  $\frac{\nu_V P_I}{N_H} \beta_V S H_C$ . All newly infected patients enter the infected population with infection age 0.

Next, we determine equations for the HCWs, beginning with the incidence. while the system describing the HCWs colonization is the following

$$\text{HCW equation} \left\{ \begin{array}{l} \frac{dH_U(t)}{dt} = \nu_H N_H - \nu_H H_U(t) - \frac{\nu_V P_C}{N_P} H_U(t) \int_0^\infty \gamma(a) i(t, a) da \\ \frac{dH_C(t)}{dt} = \frac{\nu_V P_C}{N_P} H_U(t) \int_0^\infty \gamma(a) i(t, a) da - \nu_H H_C(t) \\ H_U(0) = H_{U0} \geq 0 \\ H_C(0) = H_{C0} \geq 0. \end{array} \right. \quad (1.3)$$

As in the patient equations, contacts occur at rate  $\nu_V$ . Let  $P_C \in (0, 1]$  be the maximum probability that a contact between an infected patient and an uncontaminated HCW leads to a new contamination. The relative infectivity of patients of infection age  $a$  is  $\gamma(a)$  and the density of contacts with patients of infection age  $a$  is  $\frac{i(t, a)}{N_P}$ , where  $N_P$  is the total number of patients. Thus, the incidence of new contaminations in the HCW population is  $\frac{\nu_V P_C}{N_P} H_U \int_0^{+\infty} \gamma(a) i(t, a) da$ . The decontamination rate for HCWs is  $\nu_H$ .

The meaning of the parameters, as well as the values used in simulations, are listed in Table 1.

Symbol	Interpretation	Value	Units
$N_P$	total number of patients	400*	-
$N_H$	total number of HCWs	100*	-
$T_H = \frac{1}{\nu_H}$	average time during which an HCW stays colonized	1*	hours
$T_V = \frac{1}{\nu_V}$	average duration of visit to a patient by a HCW plus time to the next visit	1.58***	hours
$T_R = \frac{1}{\nu_R}$	average time spent in the hospital for an infected patient	28*	days
$P_I$	probability for a patient to be infected by a HCW per visit	0.06**	-
$P_C$	probability for a HCW to be colonized by a patient per visit	0.4**	-
$\gamma(a)$	relative infectivity of patients of infection age $a$		
$\tau$	time necessary to become infectious	9.86	days

**Table 1:** The parameter values are taken from [11], and are used in numerical simulations. Values marked with \* were estimated for Beth Israel Deaconess Medical Center, Boston. Values marked with \*\* were estimated for Cook County Hospital, Chicago. The parameter value  $\tau$  is estimated in this work.

By using (1.1), the system (1.2)-(1.3) can be reduced to the following system

$$\begin{cases} \frac{\partial i(t, a)}{\partial t} + \frac{\partial i(t, a)}{\partial a} = -\nu_R i(t, a), \\ i(t, 0) = \frac{\nu_V P_I \beta_V}{N_H} \left( N_P - \int_0^{+\infty} i(t, a) da \right) H_C(t) \\ \frac{dH_C(t)}{dt} = \frac{\nu_V P_C}{N_P} (N_H - H_C(t)) \int_0^{\infty} \gamma(a) i(t, a) da - \nu_H H_C(t) \\ i(0, \cdot) = i_0 \in L_+^1(0, +\infty), H_C(0) = H_{C0} \geq 0. \end{cases} \quad (1.4)$$

Assuming for simplicity that

$$\gamma(a) = \begin{cases} 1, & a \in [\tau, +\infty) \\ 0, & \text{otherwise.} \end{cases} \quad (1.5)$$

By setting

$$I(t) := \int_0^{+\infty} i(t, a) da, \quad (1.6)$$

the system (1.4) can be rewritten for  $t \geq \tau$ ,

$$\begin{cases} \frac{dI(t)}{dt} = \frac{\nu_V P_I \beta_V}{N_H} (N_P - I(t)) H_C(t) - \nu_R I(t) \\ \frac{dH_C(t)}{dt} = \frac{\nu_V P_C}{N_P} (N_H - H_C(t)) e^{-\nu_R \tau} I(t - \tau) - \nu_H H_C(t) \\ I(t, \cdot) = I_0(t) \geq 0, \forall t \in [-\tau, 0], H_C(0) = H_{C0} \geq 0. \end{cases} \quad (1.7)$$

The global asymptotic behavior of system (1.2)-(1.3) has been studied in [20]. For example the basic reproductive number for system (1.7) is given by

$$\mathcal{R}_0 = \sqrt{\frac{\nu_V^2}{\nu_H \nu_R} P_I \beta_V P_C e^{-\nu_R \tau}}. \quad (1.8)$$

The above formula suggests that the parameters  $\tau$  play a crucial role for the persistence (or the invasion) of resistant pathogens. Clearly, these parameters are related to antibiotic treatment (see D'Agata et al. [11]). At the level of single patient, antibiotic treatment provides an in-host environment that selects in favour of the resistant strain. As a consequence, due to antibiotic treatment, patients may become more likely to transmit resistant pathogens. But the effects of treatments for a single patient is a fairly complex system. Some mechanisms involved in such problems have been described in [12, 1] (see also references therein).

As far as we know no singular perturbation results are known for such age structured systems. Moreover relatively few examples have been considered in the literature. We refer to Arino et al. [4] and Ducrot et al. [15] for two examples of singularly perturbed age structured systems. One may also observe that for the functional differential equations (1.7) (as far as we know) the usual theory does not apply (see Hale and Verduyn Lunel [17] Diekmann et al. [14], Arino et al. [3], and Smith [25]). We also refer to Magalhães [21, 22] and Artstein and Slemrod [5] for more results on singular perturbation in the context of delay differential equations.

In order to introduce the singularly perturbed system a discussion of the processes is in order. First the goal of the model is to describe the spread of the hospital epidemic over several months. We observe that on the scale of one month year, a HCW visit of an average period  $\frac{1}{\nu_V} \approx 1.5$  hours is very short. Thus, we should use the idea of slow-fast system which has been successfully used for several classes of bio-medical problems (see Auger et al. [6], Hek [18]). The fast process corresponds here to HCW visit during which that contamination may happen while the slow processes correspond to patient infection, admission, and exit. Here we set  $\frac{1}{\nu_V} = \varepsilon \ll 1$ . In order to re-scale (1.7) with respect to  $\varepsilon$ , let us first notice that parameter  $\frac{1}{\nu_H}$ , the average time during which an HCW stays colonized is also related to  $\varepsilon$ . Indeed the larger the visit is, the larger is the bacterial load and therefore the larger is the time during which an HCW stays colonized. Here we shall assume a simple proportional law, that is

$$\nu_H = \gamma_H \nu_V = \frac{\gamma_H}{\varepsilon}.$$

Let us also mention that the probability  $P_I$  for a patient to become infected during a HCW visit also depends on  $\frac{1}{\nu_V}$ . Indeed since patients are motionless, the contamination process arises due to manipulation of the material, the patients themselves. As a consequence, the probability  $P_I$  can be decomposed as  $P_I = \widehat{P}_I \times \frac{1}{\nu_V}$  where  $\widehat{P}_I$  denotes the probability for a patient to become infected during a unit time of HCW visit. Here we assume that  $\widehat{P}_I$  is fixed so that

$$P_I = \widehat{P}_I \varepsilon.$$

On the other hand the contamination process of an HCW by the contaminated patient and described by  $P_C$  is rather different. Indeed, the contamination of the environment holds as soon as the patient is contaminated. This environmental contamination occurs due to the bacterial spread as well as the manipulation

of the material by the HCW. As a consequence, a contaminated patient and his environment ensure a rather strong probability of HCW colonization even if the visit time is small. Hence we decompose the probability  $P_C$  into two terms  $P_C = P_C^0 + \widehat{P}_C \times \frac{1}{\nu_V}$  wherein  $P_C^0 > 0$  corresponds to the initial probability of an HWC to become colonized as soon as he enters the contaminated environment while  $\widehat{P}_C$  corresponds to an additional probability to become colonized per unit time of visit. As a consequence one has

$$P_C := P_C(\varepsilon) = P_C^0 + \widehat{P}_C \varepsilon.$$

As a consequence of the above modelling system (1.7) re-writes as

$$\begin{cases} \frac{dI(t)}{dt} = \frac{\widehat{P}_I \beta_V}{N_H} \left( N_P - \int_0^{+\infty} i(t, a) da \right) H_C(t) - \nu_R I(t) \\ \varepsilon \frac{dH_C(t)}{dt} = \frac{P_C(\varepsilon)}{N_P} (N_H - H_C(t)) e^{-\nu_R \tau} I(t - \tau) - \gamma_H H_C(t) \\ I(t, \cdot) = I_0(t) \geq 0, \forall t \in [-\tau, 0], H_C(0) = H_{C0} \geq 0. \end{cases} \quad (1.9)$$

Formally, when  $\varepsilon = 0$  the second equation of the above system gives

$$H_C(t) = h(I(t - \tau)) \quad (1.10)$$

where  $h : [0, +\infty) \rightarrow [0, +\infty)$

$$h(x) := \frac{\beta N_H x}{\gamma_H + \beta x}, \text{ with } \beta := \frac{P_C^0}{N_P} e^{-\nu_R \tau}.$$

The so called reduced system corresponds to the first equation of (1.9) (i.e. the slow equation of (1.9)) in which  $H_C(t)$  is replaced by  $h(I(t - \tau))$ . Therefore the result model is nothing but the following single delay differential equation

$$\frac{dI(t)}{dt} = \frac{\widehat{P}_I \beta_V}{N_H} (N_P - I(t)) h(I(t - \tau)) - \nu_R I(t). \quad (1.11)$$

In section 2, we will provide a careful comparison between the solutions of system (1.9) and the solution of system (1.11). A question left for future investigation is the comparison of the original model with age of infection with the following model

$$\begin{cases} \frac{\partial i(t, a)}{\partial t} + \frac{\partial i(t, a)}{\partial a} = -\nu_R i(t, a), \\ i(t, 0) = \frac{\widehat{P}_I \beta_V}{N_H} \left( N_P - \int_0^{+\infty} i(t, a) da \right) h \left( \int_0^{+\infty} \gamma(a) i(t, a) da \right) \\ i(0, \cdot) = i_0 \in L_+^1(0, +\infty). \end{cases} \quad (1.12)$$

One may observe that this reduced model also corresponds to the model introduced in Webb et al. in [26]. We refer to [9, 13, 16, 23] (and the references therein) for more results on this nosocomial infections modelling.

The plane of the paper is the following. In section 2, we summarize the main results of this article. Section 3 is devoted to deriving preliminary result that will be used to the proof of Theorem 2.1 in Section 4. Finally Section 5 is devoted to the study of the convergence as  $\varepsilon \rightarrow 0$  to the unique heteroclinic solution of the reduced system.

## 2 Main results

For simplicity we fix  $\widehat{P}_C = 0$ , so we assume that  $P_C(\varepsilon) \equiv P_C^0$ . Then by introducing the prevalence  $x^\varepsilon = \frac{I}{N_P}$  and  $y^\varepsilon = \frac{H_C}{N_H}$ , system (1.9) can be rewritten as the following delay differential equation

$$\begin{cases} \frac{dx^\varepsilon(t)}{dt} = -\mu x^\varepsilon(t) + \alpha y^\varepsilon(t)(1 - x^\varepsilon(t)), \quad \forall t \geq 0, \\ \varepsilon \frac{dy^\varepsilon(t)}{dt} = -\nu y^\varepsilon(t) + \beta x^\varepsilon(t - \tau)(1 - y^\varepsilon(t)), \quad \forall t \geq 0, \\ y^\varepsilon(0) = y_0 \in \mathbb{R}, \\ x^\varepsilon(\theta) = \varphi(\theta), \quad \forall \theta \in [-\tau, 0], \end{cases} \quad (2.1)$$

wherein we have set

$$\mu = \nu_R, \quad \alpha = \frac{\widehat{P}_I \beta_V}{N_H}, \quad \nu = \gamma_H \text{ and } \beta = \frac{P_C^0}{N_P} e^{-\nu_R \tau}, \quad (2.2)$$

while  $\varepsilon \in (0, 1)$  is a small parameter. Note that using the above notations,  $R_0$  defined in (1.8) re-writes as

$$R_0 := \sqrt{\frac{\alpha \beta}{\mu \nu}}. \quad (2.3)$$

Let  $C := C([- \tau, 0], \mathbb{R})$  be the Banach space of continuous functions from  $[- \tau, 0]$  to  $\mathbb{R}$  endowed with the supremum norm

$$\|\varphi\|_C := \sup_{\theta \in [-\tau, 0]} |\varphi(\theta)|.$$

By taking  $\varepsilon = 0$  in equation (2.1) and solving the second equation in  $y$ , we obtain  $y(t) = \frac{\beta x(t - \tau)}{\beta x(t - \tau) + \nu}$ . By replacing  $y$  by this expression in the first equation of system (2.1), we obtain the reduced equation of (2.1)

$$\begin{cases} \frac{dx(t)}{dt} = -\mu x(t) + \alpha h(x(t - \tau))(1 - x(t)), \quad \forall t \geq 0, \\ x(\theta) = \varphi(\theta), \quad \forall \theta \in [-\tau, 0], \end{cases} \quad (2.4)$$

where the function  $h : \mathbb{R}_+ \rightarrow \mathbb{R}_+$  is defined by

$$h(x) := \frac{\beta x}{\beta x + \nu}, \quad \forall x \geq 0. \quad (2.5)$$

Set

$$M := C([- \tau, 0], [0, 1]) \times [0, 1]. \quad (2.6)$$

The main results are stated as follows.

**Theorem 2.1** Let  $\tau, \mu, \alpha, \nu, \beta > 0$  be given positive constants and let  $\begin{pmatrix} y_0 \\ \varphi \end{pmatrix} \in M$ . Let  $(x^\varepsilon, y^\varepsilon)$  (resp.  $x$ ) be the solution of (2.1) with initial data  $(\varphi, y_0) \in M$  (resp. of (2.4) with initial data  $\varphi$ ) with

$$\varphi \neq 0_C.$$

Then the following properties are satisfied

$$\limsup_{\varepsilon \rightarrow 0} \sup_{t \geq 0} |x^\varepsilon(t) - x(t)| = 0$$

and

$$\lim_{\varepsilon \rightarrow 0} \sup_{t \geq \varepsilon |\ln \varepsilon|} |y^\varepsilon(t) - h(x(t - \tau))| = 0.$$

**Remark 2.2** If  $R_0 \leq 1$  and  $\varphi \equiv 0$  then the above uniform convergence holds true.

**Remark 2.3** By using the classical change of time scale

$$x(t) = x^\varepsilon(\varepsilon t) \text{ and } y(t) = y^\varepsilon(\varepsilon t),$$

system (2.1) becomes

$$\begin{aligned} \frac{dx(t)}{dt} &= \varepsilon [-\mu x(t) + \alpha y(t)(1 - x(t))], \\ \frac{dy(t)}{dt} &= -\nu y(t) + \beta x(t - \tau_\varepsilon)(1 - y(t)). \end{aligned} \tag{2.7}$$

where  $\tau_\varepsilon := \frac{\tau}{\varepsilon} \rightarrow +\infty$  as  $\varepsilon (> 0) \rightarrow 0$ . One may observe that the equation remains singular after this change of time scale since the delay  $\tau_\varepsilon$  goes to infinity as  $\varepsilon \rightarrow 0$ . To the best of our knowledge the only available nonlinear theory is concerned with convergence local in time towards the reduced system. We refer to Artstein and Slemrod [5] and the references therein for general results on this topic.

**Remark 2.4** Roughly speaking the proof of the above result shows that in a very fast time  $t_\varepsilon$  of order  $\varepsilon |\ln \varepsilon|$ ,  $y^\varepsilon(t_\varepsilon)$  becomes very close to  $h(\varphi(t_\varepsilon - \tau))$ . Next  $y^\varepsilon(t)$  stays close to  $h(x^\varepsilon(t - \tau))$  with the following kind of estimate for  $t \geq \tau$  and  $\varepsilon$  small enough:

$$y^\varepsilon(t) = h(x^\varepsilon(t - \tau)) + O(\varepsilon) + O\left(e^{-\frac{\nu(t-\tau)}{\varepsilon}}\right).$$

It is important to point out the fact that the above theorem is established in the context that the same initial condition  $\varphi$  is taken for the system (2.1) and (2.4). When  $\varphi$  is the zero function we do not have a global uniform convergence of  $x^\varepsilon$  to  $x$  whenever  $y_0 \neq 0$  and  $R_0 > 1$ . The study of the convergence of  $x^\varepsilon$  to  $x$  is much more delicate. The result obtained is the following



**Theorem 2.5** *Assume that  $R_0 > 1$ . Then the reduced system (2.4) has a unique (up to time shift) heteroclinic orbit  $x^\infty$  such that*

$$\lim_{t \rightarrow -\infty} x^\infty(t) = 0 \text{ and } \lim_{t \rightarrow +\infty} x^\infty(t) = \bar{x} := \frac{\alpha\beta - \mu\nu}{\alpha\beta + \mu\beta}. \quad (2.8)$$

Furthermore  $x^\infty$  is increasing on  $\mathbb{R}$ .

Let  $y_0 \in (0, 1]$  be given and let us denote by  $(x^\varepsilon, y^\varepsilon)$  the solution of (2.1) with initial data  $(0_C, y_0)$ . Define

$$t_\varepsilon := \sup \left\{ t \geq 0 : x^\varepsilon(t) = \frac{\bar{x}}{2} \right\} < +\infty.$$

Then we have

$$\lim_{\varepsilon \rightarrow 0} t_\varepsilon = +\infty$$

and

$$\lim_{\varepsilon \rightarrow 0} x^\varepsilon(t + t_\varepsilon) = x^\infty(t),$$

uniformly in  $t$  on each interval of the form  $[-T, +\infty)$  with  $T \geq 0$  and where  $x^\infty \equiv x^\infty(t)$  is the unique heteroclinic orbit of the reduced system (2.4) satisfying

$$x^\infty(0) = \frac{\bar{x}}{2}.$$

In order to illustrate the latter results and more specifically Theorem 2.1 with realistic parameters, we shall use the values described in Table 1. Notice that the average time necessary to become infectious, namely  $\tau$ , is unknown and needs to be estimated. This is performed by using the expression of the endemic prevalence equilibrium  $\bar{x}$  given in (2.8). Using the parameters of Table 1, to reach 10% prevalence of patient we obtain  $\tau = 9.86 \text{ days}$ . Figure 2-(a) illustrates how the equilibrium prevalence of patients varies with respect to the parameters  $\tau$  and  $\frac{1}{\nu_V}$ . Note that the prevalence is very sensitive with respect to the average time of HCW visit. Indeed for the value  $\tau = 9.86 \text{ days}$  the prevalence at equilibrium varies from 10% to 18% when the length of visit varies from 95 min to 90 min. Figure 2-(b) illustrates the dependence on the basic reproduction number  $R_0$  with respect to  $\tau$  and  $\frac{1}{\nu_V}$ . An increasing of the length of visit  $\frac{1}{\nu_V}$  leads to a decrease of the basic reproduction number and thus on the bacteria's spread.

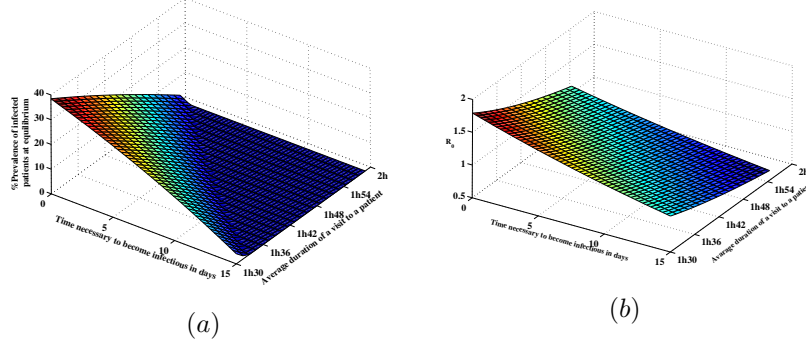

Figure 2: Figures (a) and (b) describe respectively the evolution of the prevalence of infected patients at the equilibrium and  $R_0$  with respect to  $1/\nu_V$  and  $\tau$ .

Finally the convergence result stated in Theorem 2.1 is illustrated in Figure 3. The error between the prevalence for the full and reduced system is plotted for different values for the time of HCW visit. Together with the parameters of Table 1 and the different values of  $\nu_V$  recalled in Figure 3, we obtain a maximal error of order  $10^{-3}$  over one year's computation time.

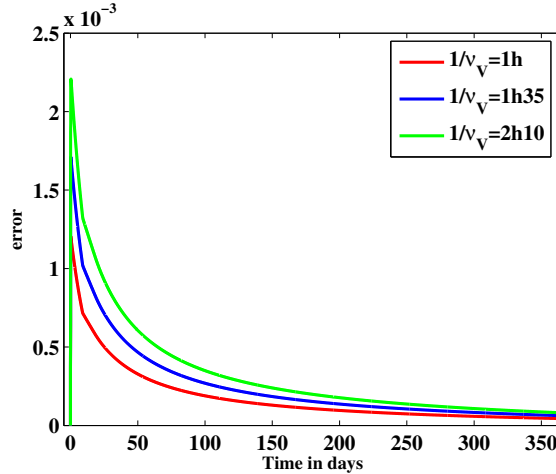

Figure 3: Error between the full and the reduced system for the same non zero initial data and different  $\nu_V$ . Precisely  $\text{error}(t) = |x^\epsilon(t) - x(t)|$ , the parameters  $\nu, \mu, \alpha, \beta$  are computed using the relation (2.2) with the approximation  $P_C^0 = P_C$  for the parameter value of the Table 1. The initial data for  $y$  is  $y_0 = 0.5$  and the initial data for  $x$  and  $x^\epsilon$  is  $\varphi(t) = 0.6$  for  $t \in [-9.86, 0]$ .

### 3 Preliminaries

The aim of this section is to derive preliminary results for (2.1) and (2.4). We shall more specifically focus on existence and uniqueness of solution as well as asymptotic behavior. We shall use the usual history function to deal with delay differential equation, namely for each continuous function  $x : [-\tau, T) \rightarrow \mathbb{R}$  for some given  $T > 0$  we write  $t \in [0, T) \mapsto x_t \in C$  defined by  $x_t(\theta) = x(t + \theta)$  for each  $\theta \in [-\tau, 0]$  and  $t \in [0, T)$ . We first state the preliminary result for the reduced system (2.4).

**Lemma 3.1** *Consider the set*

$$\hat{M} := \{\varphi \in C : 0_C \leq \varphi \leq 1_C\}. \quad (3.1)$$

*Then  $\hat{M}$  is positively invariant with respect to the semiflow generated by (2.4). If we denote by  $\{U(t)\}_{t \geq 0}$  the strongly continuous semiflow on  $\hat{M}$  generated by (2.4) defined by  $U(t)\varphi = x_t$  the following holds true:*

(i) for each  $(\varphi, \psi) \in (\hat{M})^2$

$$\varphi \leq \psi \Rightarrow U(t)\varphi \leq U(t)\psi, \forall t \geq 0. \quad (3.2)$$

(ii) *When  $R_0 \leq 1$  then the semiflow  $U$  only has the trivial equilibrium  $0_C$ . When  $R_0 > 1$  the semiflow admits exactly two equilibrium points: the trivial one and the constant  $\bar{x}$  defined by*

$$\bar{x} := \frac{\alpha\beta - \mu\nu}{\alpha\beta + \mu\beta}. \quad (3.3)$$

(iii) *When  $R_0 \leq 1$  then the trivial equilibrium  $0_C$  is globally asymptotically stable in  $\hat{M}$ . When  $R_0 > 1$  then the positive equilibrium  $\bar{x}$  is globally asymptotically stable in  $\hat{M} \setminus \{0_C\}$ .*

*Proof.* The proof of the forward invariance of  $\hat{M}$  as well as (i) directly follows from the results of Smith [24]. Indeed if we define  $g : C \rightarrow \mathbb{R}$  by

$$g(\psi) := -\mu\psi(0) + \alpha h(\psi(-\tau))(1 - \psi(0)).$$

Then one has  $g(1_C) \leq 0$  and  $g(0_C) = 0$  so that  $\hat{M}$  is forward invariant and on  $\hat{M}$  function  $g$  is quasi monotone. Now the proof (ii) comes from straightforward computations. It remains to prove (iii). To do so let us first notice that

$$\lim_{\delta \rightarrow 0} \frac{g(\delta 1_C)}{\delta} = -\mu + \frac{\alpha\beta}{\nu} = \mu [R_0^2 - 1] > 0.$$

Then using the results of Smith [24] for each  $\delta \in (0, 1)$  small enough we have  $U(t)(\delta 1_C) \rightarrow \bar{x}$  as  $t \rightarrow +\infty$ . On the other hand let us also notice that  $g(1_C) < 0$

so that we deduce using (i) that  $U(t)1_C \rightarrow \bar{x}$  as  $t \rightarrow \infty$ . To complete the proof (iii) it remains to show that for each  $\varphi \in \hat{M} \setminus \{0_C\}$  the solution  $t \rightarrow x_t = U(t)\varphi$  of the system (2.4) satisfies  $x(t) > 0$  for all  $t \geq \tau$ . Since  $\varphi \in \hat{M} \setminus \{0_C\}$  there exists  $t_0 \in [0, \tau]$  such that  $x(t_0) > 0$ . Hence one gets for each

$$\begin{aligned} x(t) &= e^{-\mu(t-t_0)}x(t_0) + \int_{t_0}^t e^{-\mu(t-s)}\alpha h(x(s-\tau))(1-x(s))ds \\ &\geq e^{-\mu(t-t_0)}x(t_0) > 0, \quad \forall t \geq t_0, \end{aligned}$$

and the result follows. ■

Let us now state a similar preliminary result for System (2.1).

**Lemma 3.2** *Let  $\varepsilon > 0$  be given. Then the subset  $M \subset C \times \mathbb{R}$  (defined in (2.6)) is positively invariant by the semiflow generated by (2.1). If we denote by  $\{U^\varepsilon(t)\}_{t \geq 0}$  the continuous semiflow on  $M$  generated by (2.1) defined by  $U^\varepsilon(t)\varphi = (x_t^\varepsilon, y^\varepsilon(t))^T$  then the following holds true:*

(i) for each  $(\varphi, \psi) \in (M)^2$ :

$$\varphi \leq_{C \times \mathbb{R}} \psi \Rightarrow U(t)\varphi \leq_{C \times \mathbb{R}} U(t)\psi, \quad \forall t \geq 0, \quad (3.4)$$

where the partial order  $\leq_{C \times \mathbb{R}}$  is defined by the usual positive cone  $C_+ \times \mathbb{R}^+ \subset C \times \mathbb{R}$ .

(ii) When  $R_0 \leq 1$  then the only equilibrium of the semiflow  $U^\varepsilon$  is the trivial equilibrium  $(0_C, 0)^T$ . When  $R_0 > 1$  the semiflow admits exactly two equilibrium points: the trivial one and the constant  $(\bar{x}, \bar{y})^T$  where  $\bar{x}$  is defined in (3.3) while  $\bar{y} = h(\bar{x})$ .

(iii) When  $R_0 \leq 1$  then the trivial equilibrium  $(0_C, 0)^T$  is globally asymptotically stable in  $M$ . When  $R_0 > 1$  then the interior equilibrium  $(\bar{x}, \bar{y})^T$  is globally asymptotically stable in  $M \setminus \{(0_C, 0)\}$ .

The proof of this results is straightforward and follows by the same steps and arguments as the one of Lemma 3.1.

Our next preliminary result relies on some property of the entire solutions of the reduced system (2.4). This will be needed in the proof of Theorem 2.1 as well as Theorem 2.5.

**Lemma 3.3** *Assume that  $R_0 > 1$ . Then  $\{x(t)\}_{t \in \mathbb{R}}$  is a complete orbit in  $\hat{M}$  of (2.4) if and only if one of the following property is satisfied:*

(i)  $x$  is an equilibrium point of the system (2.4), namely  $x(t) \equiv 0_C$  or  $x(t) \equiv \bar{x}$ .

(ii)  $x$  is a heteroclinic orbit of the system (2.4) satisfying the following properties

- (a)  $0 < x(t) \leq \bar{x}$  for all  $t \in \mathbb{R}$ .  
(b)  $\lim_{t \rightarrow +\infty} x(t) = \bar{x}$  and  $\lim_{t \rightarrow -\infty} x(t) = 0$ .

*Proof.* Let us first notice that (i) or (ii) implies that  $x$  is a complete orbit of (2.4) in  $\hat{M}$ . Let  $\{x(t)\}_{t \in \mathbb{R}}$  be a given complete orbit of the system (2.4) in  $\hat{M}$  such that  $x \neq 0_C$  and  $x \neq \bar{x}$ .

Let us first prove that  $x$  satisfies (ii)-(a). Since  $x(t) \in \hat{M}$  for each  $t \in \mathbb{R}$  one has  $0_C \leq x_{t-s} \leq 1_C$  for each  $t \in \mathbb{R}$  and  $s \in \mathbb{R}$ . Lemma 3.1-(i) yields that  $0_C \leq x_t \leq U(s)1_C$  for each  $s \geq 0$  and  $t \in \mathbb{R}$ . Lemma 3.1-(iii) implies that  $U(s)1 \rightarrow \bar{x}$  as  $s \rightarrow +\infty$  that ensures that  $0 \leq x(t) \leq \bar{x}$  for all  $t \in \mathbb{R}$ . To complete the proof of (ii)-(a) it remains to prove that  $0 < x(t)$  for all  $t \in \mathbb{R}$ . To prove this property let us argue by contradiction by assuming that there exists  $\tilde{t} \in \mathbb{R}$  such that  $x(\tilde{t}) = 0$ . Let us first notice that from the reduced system, one gets

$$\frac{d[e^{\mu t}x(t)]}{dt} = e^{\mu t}h(x(t-\tau))(1-x(t)) \geq 0, \quad \forall t \in \mathbb{R},$$

so that  $t \mapsto e^{\mu t}x(t)$  is non-decreasing. Hence  $x(t) = 0$  for all  $t \leq \tilde{t}$ . Since  $x(t) \equiv 0$  on  $[\tilde{t}-\tau, \tilde{t}]$  one concludes that  $x(t) = 0$  for all  $t \geq \tilde{t}$ . We obtain that  $x(t) \equiv 0$ , a contradiction that completes the proof of (ii)-(a).

It remains to prove (ii)-(b). First since  $x \neq 0_C$ , Lemma 3.1-(iii) yields that  $x(t) \rightarrow \bar{x}$  as  $t \rightarrow \infty$ . As a consequence we only need to show that  $x(t) \rightarrow 0$  as  $t \rightarrow -\infty$ . This property is related to the following functional

$$V(x_t) := x(t) + \mu \int_{t-\tau}^t x(s) ds, \quad \forall t \in \mathbb{R}. \quad (3.5)$$

Straightforward computations yields that

$$\frac{dV(x_t)}{dt} = h(x(t-\tau))[\alpha(\bar{x} - x(t)) + \mu(\bar{x} - x(t-\tau))], \quad \forall t \in \mathbb{R}. \quad (3.6)$$

Then due to (ii)-(a),  $x(t) \leq \bar{x}$  for all  $t \in \mathbb{R}$  and  $t \mapsto V(x_t)$  is non-decreasing. To conclude let us consider a decreasing sequence  $\{t_n\}_{n \geq 0}$  such that  $t_n \rightarrow -\infty$  as  $n \rightarrow +\infty$ . Let us define the uniformly bounded sequence of shifted maps  $\{x^n\}_{n \geq 0}$  be

$$x^n(t) = x(t + t_n), \quad \forall t \in \mathbb{R}.$$

Since  $x^n$  is an entire solution of (2.4) and since  $\{x^n\}$  is uniformly bounded, one concludes that  $\{\frac{dx^n}{dt}\}_{n \geq 0}$  is also uniformly bounded. As a consequence, possibly along a sub-sequence, one may assume that  $x^n(t) \rightarrow x^\infty(t)$  as  $n \rightarrow \infty$  locally uniformly in  $t \in \mathbb{R}$  and wherein  $x^\infty$  is also an entire solution in  $\hat{M}$  of (2.4). Next for each  $n \geq 0$  and  $K > 0$ , integrating (3.6) over  $[t_n - K, t_n + K]$  yields

$$\begin{aligned} V(x_{t_n+K}) &= \int_{-K}^K h(x^n(t-\tau))[\alpha(\bar{x} - x^n(t)) + \mu(\bar{x} - x^n(t-\tau))] dt \\ &\quad + V(x)(t_n - K). \end{aligned}$$

Since  $t \mapsto V(x_t)$  is non-increasing and bounded from below one obtains when  $n \rightarrow +\infty$  that

$$\int_{-K}^K h(x^\infty(t-\tau)) [\alpha(\bar{x} - x^\infty(t)) + \mu(\bar{x} - x^\infty(t-\tau))] dt = 0, \quad \forall K > 0.$$

This implies that

$$h(x^\infty(t-\tau)) [\alpha(\bar{x} - x^\infty(t)) + \mu(\bar{x} - x^\infty(t-\tau))] \equiv 0,$$

so that  $x^\infty(t) \equiv 0$  or  $x^\infty(t) \equiv \bar{x}$ . To conclude the proof we need to prove that  $x^\infty(t) \equiv 0$ . Let us argue by contradiction by assuming that  $x^\infty(t) \equiv \bar{x}$ . Then the functional  $\varphi \rightarrow V(\varphi)$  is monotone increasing therefore

$$x_t \leq \bar{x}1_C \Rightarrow V(x_t) \leq V(\bar{x})$$

since  $t \in \mathbb{R} \mapsto V(x_t)$  is non-decreasing we also have

$$V(\bar{x}) \leq V(x_t).$$

Therefore

$$V(x_t) = V(\bar{x}), \quad \forall t \in \mathbb{R},$$

As a consequence  $\frac{V(x_t)}{dt} \equiv 0$  that re-writes as

$$h(x(t-\tau)) [\alpha(\bar{x} - x(t)) + \mu(\bar{x} - x(t-\tau))] \equiv 0,$$

so that  $x(t) \equiv 0$  or  $x(t) \equiv \bar{x}$ , a contradiction. The proof is completed. ■

## 4 Proof of Theorem 2.1

The aim of this section is to prove Theorem 2.1. This proof is divided into two parts. The first part is devoted to the convergence  $x_t^\varepsilon \rightarrow x_t$  as  $\varepsilon(> 0) \rightarrow 0$ . The second part is related the behavior of  $t \rightarrow y^\varepsilon(t)$ .

### 4.1 Convergence of $t \mapsto x^\varepsilon(t)$

In order to investigate the uniform convergence of  $x^\varepsilon$  let us first prove the following local uniform convergence:

**Lemma 4.1 (Local uniform convergence)** *Let  $\begin{pmatrix} y_0 \\ \varphi \end{pmatrix} \in M$  be given. Let  $x$  be the solution of (2.4) with initial data  $\varphi$ . Then for each  $\hat{\tau} > 0$  we have*

$$\lim_{\varepsilon \rightarrow 0} \sup_{t \in [-\tau, \hat{\tau}]} |x^\varepsilon(t) - x(t)| = 0,$$

and

$$\lim_{\varepsilon \rightarrow 0} \int_0^{\hat{\tau}} y^\varepsilon(t) \psi(t) dt = \int_0^{\hat{\tau}} h(x(t-\tau)) \psi(t) dt, \quad \forall \psi \in L^1(0, \hat{\tau}; \mathbb{R}).$$

Note that the proof of the above result can be directly obtained using the theory of Artstein and Slemrod in [5]. For the sake of completeness we provide a direct and easy proof that takes into account the particular structure of our system to conclude to the local weak star convergence for the  $y$ -component. Let us also notice that since the work of Artstein and Slemrod [5] deals with Young measure narrow convergence for the  $y$ -component, it allows to conclude to the (local) strong  $L^1$ -convergence of  $y^\varepsilon(t)$  to  $h(x(t-\tau))$ . Such a strong convergence will be derived latter on by deriving direct uniform estimates as well as layer time estimates.

*Proof.* The proof of the above result also relies on Arzela-Ascoli's theorem. Since  $\{(x^\varepsilon, y^\varepsilon)\}_{\varepsilon \in (0,1)} \subset C([0, \infty), M)$  is uniformly bounded, one gets by using (2.1) that  $\{\frac{dx^\varepsilon}{dt}\}_{\varepsilon \in (0,1)}$  is also uniformly bounded in  $C([0, \infty), \mathbb{R})$ . Since  $x_0^\varepsilon = \varphi$  for all  $\varepsilon \in (0, 1)$  we infer from Arzela-Ascoli's theorem that  $\{x^\varepsilon\}_{\varepsilon \in (0,1)}$  is relatively compact in  $C_{loc}([-\tau, \infty), \hat{M})$  while due to Banach-Alaoglu-Bourbaki's theorem  $\{y^\varepsilon\}_{\varepsilon \in (0,1)}$  is relatively compact for the weak-\* topology of  $\sigma(L_{loc}^\infty((0, \infty), \mathbb{R}), L_{loc}^1((0, \infty), \mathbb{R}))$ .

Let  $\hat{\tau} > 0$  be given and let  $\{\varepsilon_n\}_{n \geq 1} \subset (0, 1)$  be a given sequence tending to 0 as  $n \rightarrow \infty$ . Up to a sub-sequence, one may assume that  $x^{\varepsilon_n} \rightarrow x^0 \in C([-\tau, \hat{\tau}], \hat{M})$  uniformly on  $[-\tau, \hat{\tau}]$  with  $x^0(\theta) = \varphi(\theta)$  for each  $\theta \in [-\tau, 0]$  and  $y^{\varepsilon_n} \xrightarrow{*} y_0 \in L^\infty((0, \hat{\tau}), \mathbb{R})$  for the weak-\* topology of  $L^\infty((-\tau, \hat{\tau}), \mathbb{R})$ . That is to say that for each  $\hat{\tau} \in (0, +\infty)$

$$\lim_{n \rightarrow +\infty} \int_0^{\hat{\tau}} y^{\varepsilon_n}(t) \phi(t) dt = \int_0^{\hat{\tau}} y^0(t) \phi(t) dt, \forall \phi \in L^1((0, \hat{\tau}), \mathbb{R}).$$

It follows that

$$\int_0^{\hat{\tau}} y^0(t) \phi(t) dt \geq 0 \text{ and } \int_0^{\hat{\tau}} [1 - y^0(t)] \phi(t) dt \geq 0, \forall \phi \in L_+^1((0, \hat{\tau}), \mathbb{R}).$$

Since  $\hat{\tau} < +\infty$ , we deduce that

$$y^0 \in L^1((0, \hat{\tau}), \mathbb{R})$$

and

$$\int_0^{\hat{\tau}} y^0(t) \phi(t) dt \geq 0 \text{ and } \int_0^{\hat{\tau}} [1 - y^0(t)] \phi(t) dt \geq 0, \forall \phi \in L_+^\infty((0, \hat{\tau}), \mathbb{R}).$$

Now by applying the Hahn-Banach in  $L^1((0, \hat{\tau}), \mathbb{R})$ , it follows that

$$0 \leq y_0 \leq 1.$$

On the one hand, let  $\psi \in C^1([0, \hat{\tau}], \mathbb{R})$  be a given test function. Multiplying the  $y^{\varepsilon_n}$ -equation in (2.1) by  $\psi$  and integrating over  $(0, \hat{\tau})$  yields for each  $n \geq 0$

$$\begin{aligned}
& \varepsilon_n [y^{\varepsilon_n}(\hat{\tau})\psi(\hat{\tau}) - y_0\psi(0)] - \varepsilon_n \int_0^{\hat{\tau}} y^{\varepsilon_n}(t)\psi'(t) dt \\
&= \int_0^{\hat{\tau}} [\beta x^{\varepsilon_n}(t-\tau)(1-y^{\varepsilon_n}(t)) - \nu y^{\varepsilon_n}(t)]\psi(t) dt.
\end{aligned}$$

Letting  $n \rightarrow +\infty$  provides

$$\int_0^{\hat{\tau}} [\beta x^0(t-\tau)(1-y^0(t)) - \nu y^0(t)]\psi(t) dt = 0, \quad \forall \psi \in C^1([0, \hat{\tau}], \mathbb{R}),$$

so that

$$y^0(t) = h(x^0(t-\tau)) \quad a.e. \text{ for } t \in [0, \hat{\tau}]. \quad (4.1)$$

On the other hand, from the  $x^{\varepsilon_n}$ -equation in (2.1) one has for each  $n \geq 0$ :

$$x^{\varepsilon_n}(t) = \varphi(0) + \int_0^t [\alpha(1-x^{\varepsilon_n}(s))y^{\varepsilon_n}(s) - \mu x^{\varepsilon_n}(s)] ds, \quad \forall t \in [0, \hat{\tau}].$$

Letting  $n \rightarrow +\infty$  provides that

$$x^0(t) = \varphi(0) + \int_0^t [\alpha(1-x^0(s))y^0(s) - \mu x^0(s)] ds, \quad \forall t \in [0, \hat{\tau}].$$

Recalling (4.1) and that  $x^0$  satisfies  $x^0(\theta) = \varphi(\theta)$  for each  $\theta \in [-\tau, 0]$  we obtain that  $x^0 = x$  on  $[-\tau, \hat{\tau}]$ . This completes the proof of the result.  $\blacksquare$

Before proving Theorem 2.1 we need some preliminary lemmas. First we have an estimation from below of solutions independent of the parameter  $\varepsilon > 0$ .

**Lemma 4.2** *Assume that  $R_0 > 1$ . Then for all  $\begin{pmatrix} y_0 \\ \varphi \end{pmatrix} \in M$ , with  $\varphi \neq 0_C$ . Then the map  $t \mapsto w^\varepsilon(t)$  defined by*

$$w^\varepsilon(t) = x^\varepsilon(t) + \frac{\varepsilon\mu}{\beta}y^\varepsilon(t) + \mu \int_{t-\tau}^t x^\varepsilon(s) ds, \quad \forall t \geq 0, \quad (4.2)$$

satisfies the following properties:

(i) For all  $t \geq 0$  and  $\varepsilon > 0$

$$\frac{dw^\varepsilon(t)}{dt} = \alpha y^\varepsilon(t)(\bar{x} - x^\varepsilon(t)) + \mu y^\varepsilon(t)(\bar{x} - x^\varepsilon(t-\tau)).$$

(ii) There exists  $\eta > 0$  and  $\varepsilon_0 > 0$  such that

$$w^\varepsilon(t) \geq \eta, \quad \forall t \geq \tau, \forall \varepsilon \in (0, \varepsilon_0).$$



*Proof.* The proof of (i) follows from straightforward computations. In order to prove (ii), let's observe that by integrating the  $x$ -equation in system (2.1) in between  $t - \tau$  and  $t$  we obtain that

$$x^\varepsilon(t) + \mu \int_{t-\tau}^t x^\varepsilon(s) ds = x^\varepsilon(t - \tau) + \alpha \int_{t-\tau}^t y^\varepsilon(s) (1 - x^\varepsilon(s)) ds, \quad \forall t \geq \tau.$$

Thus

$$w^\varepsilon(t) = \frac{\varepsilon\mu}{\beta} y^\varepsilon(t) + x^\varepsilon(t - \tau) + \alpha \int_{t-\tau}^t y^\varepsilon(s) (1 - x^\varepsilon(s)) ds, \quad \forall t \geq \tau.$$

Since  $w^\varepsilon(t) \geq x^\varepsilon(t)$  for all  $t \geq 0$ , one obtains

$$w^\varepsilon(t) \geq \max\{x^\varepsilon(t), x^\varepsilon(t - \tau)\}, \quad \forall t \geq \tau. \quad (4.3)$$

If one sets  $x_t = U(t)\varphi$  then since  $\varphi \not\equiv 0$  one has  $x(\tau) = [U(\tau)\varphi](0) > 0$ . On the other hand due to Lemma 4.1 we know that  $x^\varepsilon(\tau) \rightarrow x(\tau)$  as  $\varepsilon \rightarrow 0$ . Thus there exists  $\varepsilon_0 > 0$  such that

$$x^\varepsilon(\tau) \geq \frac{x(\tau)}{2} > 0, \quad \forall \varepsilon \in (0, \varepsilon_0). \quad (4.4)$$

To conclude the proof of (ii) we will use the following claim.

**Claim 4.3** *Let  $\varepsilon \in (0, \varepsilon_0)$  be given. Then for each  $\delta \in (0, 1)$  such that  $\frac{\delta}{2}x(\tau) < \bar{x}$  we have*

$$w^\varepsilon(t) \geq \frac{\delta}{2}x(\tau), \quad \forall t \geq \tau.$$

To prove this claim, let us notice that by (4.3) and (4.4) we have

$$w^\varepsilon(\tau) \geq x^\varepsilon(\tau) > \frac{\delta}{2}x(\tau).$$

Let us consider

$$t_0 := \sup \left\{ t > \tau : w^\varepsilon(l) \geq \frac{\delta}{2}x(\tau), \quad \forall l \in [\tau, t] \right\}.$$

Then let us prove that

$$t_0 = +\infty.$$

Assume that  $t_0 < +\infty$ , then one has

$$w^\varepsilon(t_0) = \frac{\delta}{2}x(\tau) < \bar{x}.$$

One can therefore introduce  $t_1 > t_0$  defined by

$$t_1 = \sup \{ t > t_0 : w^\varepsilon(l) \leq \bar{x}, \quad \forall l \in [t_0, t] \}.$$

We infer from (4.3) that

$$x^\varepsilon(t) \leq \bar{x} \text{ and } x^\varepsilon(t - \tau) \leq \bar{x}, \quad \forall t \in [t_0, t_1].$$

As a consequence (i) the map  $t \mapsto w^\varepsilon(t)$  is non-decreasing on  $[t_0, t_1]$ , that implies

$$w^\varepsilon(t) \geq w^\varepsilon(t_0) \geq \frac{\delta}{2}x(\tau), \quad \forall t \in [t_0, t_1].$$

This contradicts the definition of  $t_0$  and completes the proof of (ii).  $\blacksquare$

Coupling Lemma 3.3 and Lemma 4.2 lead to the following lemma.

**Lemma 4.4** *Let us assume that  $R_0 > 1$ . Let  $\begin{pmatrix} y_0 \\ \varphi \end{pmatrix} \in M$  be given such that  $\varphi \neq 0_C$ . Then for each sequence  $\{\varepsilon_n\}_{n \geq 0} \subset (0, 1)$  and  $\{t_n\}_{n \geq 0} \subset (0, \infty)$  such that  $\varepsilon_n \rightarrow 0$  and  $t_n \rightarrow +\infty$  as  $n \rightarrow +\infty$  we have*

$$\lim_{n \rightarrow +\infty} x^{\varepsilon_n}(t + t_n) = \bar{x}, \quad \text{locally uniformly for } t \in \mathbb{R}.$$

*Proof.* Let  $\{\varepsilon_n\}_{n \geq 0}$  and  $\{t_n\}_{n \geq 0}$  be given sequences such that  $\varepsilon_n \rightarrow 0$  and  $t_n \rightarrow +\infty$  as  $n \rightarrow +\infty$ . Define the sequences of shifted maps

$$x^n(t) := x^{\varepsilon_n}(t + t_n) \in [0, 1] \text{ and } y^n(t) := y^{\varepsilon_n}(t + t_n) \in [0, 1],$$

with  $n \geq 0$  and  $t \in (-t_n, +\infty)$ , that satisfy the system of equations:

$$\begin{cases} \frac{dx^n(t)}{dt} = -\mu x^n(t) + \alpha(1 - x^n(t))y^n(t), & \forall t \geq -t_n, \\ \varepsilon_n \frac{dy^n(t)}{dt} = -\nu y^n(t) + \beta x^n(t - \tau)(1 - y^n(t)), & \forall t \geq -t_n. \end{cases}$$

Thus by using the same techniques as in the proof of Lemma 4.1, up to a subsequence, one may assume that  $x^n \rightarrow x^\infty$  locally uniformly for  $t \in \mathbb{R}$  wherein  $x^\infty$  is a complete orbit of (2.4) in  $\hat{M}$ . It remains to prove that  $x^\infty \equiv \bar{x}$  that is a consequence of the uniform persistence result stated in Lemma 4.2-(ii). Indeed, since  $\varphi \neq 0$ , there exists  $\eta > 0$  and  $N > 0$  such that for each  $n \geq N$  and each  $t \geq \tau - t_n$ :

$$x^{\varepsilon_n}(t + t_n) + \frac{\varepsilon_n \mu}{\beta} y^{\varepsilon_n}(t + t_n) + \mu \int_{t-\tau}^t x^{\varepsilon_n}(s + t_n) ds \geq \eta.$$

Letting  $n \rightarrow \infty$  yields

$$x^\infty(t) + \mu \int_{t-\tau}^t x^\infty(s) ds \geq \eta, \quad \forall t \in \mathbb{R}.$$

The classification of complete orbits of (2.4) provided by Lemma 3.3 allows us to conclude that  $x^\infty(t) \equiv \bar{x}$  and the result follows.  $\blacksquare$

We are now ready to prove the first part of Theorem 2.1.

**Theorem 4.5** Let  $\begin{pmatrix} y_0 \\ \varphi \end{pmatrix} \in M$  be given such that

$$\text{either } \varphi \neq 0 \text{ or } \begin{pmatrix} y_0 \\ \varphi \end{pmatrix} = \begin{pmatrix} 0_{\mathbb{R}} \\ 0_C \end{pmatrix}.$$

Let  $x$  be the solution of (2.4) with initial data  $\varphi$ . Then we have

$$\limsup_{\varepsilon \rightarrow 0} \sup_{t \geq 0} |x^\varepsilon(t) - x(t)| = 0. \quad (4.5)$$

**Remark 4.6** Using similar argument as in the proof of Theorem 4.5, the conclusion remains true whenever  $R_0 \leq 1$  and  $\varphi = 0$ . However when  $R_0 > 1$  then Theorem 4.5 is no longer true when  $\varphi \equiv 0$  and  $y_0 > 0$ . The question will be studied in Theorem 2.5.

*Proof.* Let us first remark that when  $\varphi = 0_C$  and  $y_0 = 0$  then (4.5) is trivially verified since

$$x^{\varepsilon_n}(t) = x(t) = 0, \forall t \geq 0, \forall \varepsilon > 0.$$

Let  $\begin{pmatrix} y_0 \\ \varphi \end{pmatrix} \in M$  with  $\varphi \neq 0$ . Assume that (4.5) is not satisfied. Then there exist  $\eta > 0$  and two sequences  $\{\varepsilon_n\}_{n \geq 0} \rightarrow 0$  and  $\{t_n\}_{n \geq 0}$  such that

$$|x^{\varepsilon_n}(t_n) - x(t_n)| > \eta, \forall n \geq 0. \quad (4.6)$$

Moreover by Lemma 4.1 we must have

$$\{t_n\}_{n \geq 0} \rightarrow +\infty.$$

Define the shifted maps

$$x^n(t) := x^{\varepsilon_n}(t + t_n) \text{ and } y^n(t) := y^{\varepsilon_n}(t + t_n),$$

for all  $n \geq 0$  and all  $t \in (-t_n, +\infty)$ . Then we have

$$0 \leq x^n(t) \leq 1 \text{ and } 0 \leq y^n(t) \leq 1,$$

for all  $n \geq 0$  and  $t \in (-t_n, +\infty)$ .

By using the same techniques as in the proof of Lemma 4.1, one may assume that  $x^n(t) \rightarrow x^\infty(t)$  locally uniformly where  $x^\infty$  is a complete orbit of (2.4) in  $\hat{M}$  such that

$$|x^\infty(0) - L| \geq \eta \quad (4.7)$$

where

$$L := \lim_{t \rightarrow +\infty} x(t).$$

So either

$$L = 0 \text{ or } L = \bar{x}.$$

According to the classification provided by Lemma 3.1-(iii) we will now split the proof into two parts: a)  $R_0 \leq 1$  and  $L = 0$ ; b)  $R_0 > 1$  and  $L = \bar{x}$ .

a) If  $R_0 \leq 1$  then  $x^\infty$  is an entire solution of (2.4) in  $\hat{M}$  so that one can deduce that  $x^\infty(t) \equiv 0$ . This is a direct consequence of Lemma 3.1 (ii) and (iii). Since  $L = 0$  we obtain a contradiction with (4.7).

b) If we consider the case when  $R_0 > 1$ . Then by Lemma 4.4 we deduce that  $x^\infty \equiv \bar{x}$ . But  $\varphi \neq 0$  we also have  $L = \bar{x}$  and we obtain a contradiction with (4.7). This completes the proof of the result.  $\blacksquare$

## 4.2 Convergence of $y^\varepsilon$

The aim of this section is to study the convergence property of  $y^\varepsilon$  as  $\varepsilon \rightarrow 0$  in order to complete the proof of Theorem 2.1. Let's start with an estimation of  $y^\varepsilon(t) - h(x^\varepsilon(t - \tau))$  for  $t \in [\tau, +\infty)$ .

**Lemma 4.7** *For each  $\varepsilon > 0$  and each initial datum  $\begin{pmatrix} y_0 \\ \varphi \end{pmatrix} \in M$  we have*

$$|y^\varepsilon(t) - h(x^\varepsilon(t - \tau))| \leq e^{-\frac{\nu}{\varepsilon}(t-\tau)} |y^\varepsilon(\tau) - h(\varphi(0))| + \kappa\varepsilon, \quad \forall t \geq \tau,$$

with

$$\kappa := \frac{\beta(\mu + \alpha)}{\nu^2}.$$

*Proof.* Let us first notice that the integration of the  $y$ -equation in (2.1) yields for each  $t \geq \tau$  to:

$$y^\varepsilon(t) = e^{-\frac{1}{\varepsilon} \int_\tau^t (\nu + \beta x^\varepsilon(l-\tau)) dl} y^\varepsilon(\tau) + \int_\tau^t e^{-\frac{1}{\varepsilon} \int_s^t (\nu + \beta x^\varepsilon(l-\tau)) dl} \frac{\beta}{\varepsilon} x^\varepsilon(s - \tau) ds. \quad (4.8)$$

Equation (4.8) may of course be re-written for each  $t \geq \tau$  as

$$y^\varepsilon(t) = e^{-\frac{1}{\varepsilon} \int_\tau^t (\nu + \beta x^\varepsilon(l-\tau)) dl} y^\varepsilon(\tau) + v^\varepsilon(t),$$

where the map  $v^\varepsilon : [\tau, \infty) \rightarrow \mathbb{R}^+$  is defined by

$$v^\varepsilon(t) := \int_\tau^t e^{-\frac{1}{\varepsilon} \int_s^t (\nu + \beta x^\varepsilon(l-\tau)) dl} \frac{\beta}{\varepsilon} x^\varepsilon(s - \tau) ds$$

then we observe that

$$\begin{aligned} v^\varepsilon(t) &= \int_\tau^t \frac{d}{ds} \left[ e^{-\frac{1}{\varepsilon} \int_s^t (\nu + \beta x^\varepsilon(l-\tau)) dl} \right] h(x^\varepsilon(s - \tau)) ds \\ &= \left[ e^{-\frac{1}{\varepsilon} \int_s^t (\nu + \beta x^\varepsilon(l-\tau)) dl} h(x^\varepsilon(s - \tau)) \right]_{s=\tau}^{s=t} \\ &\quad - \int_\tau^t \frac{d}{ds} \left[ e^{-\frac{1}{\varepsilon} \int_s^t (\nu + \beta x^\varepsilon(l-\tau)) dl} \right] h'(x^\varepsilon(s - \tau)) \frac{dx^\varepsilon}{dt}(s - \tau) ds \end{aligned}$$

Therefore for each  $t \geq \tau$  one has

$$v^\varepsilon(t) - h(x^\varepsilon(t - \tau)) = -e^{-\frac{1}{\varepsilon} \int_\tau^t (\nu + \beta x^\varepsilon(l - \tau)) dl} h(\varphi(0)) - w^\varepsilon(t),$$

with

$$w^\varepsilon(t) = \int_\tau^t e^{-\frac{1}{\varepsilon} \int_s^t (\nu + \beta x^\varepsilon(l - \tau)) dl} h'(x^\varepsilon(s - \tau)) \frac{dx^\varepsilon}{dt}(s - \tau) ds.$$

Together with these notations, one gets for each  $t \geq \tau$

$$|y^\varepsilon(t) - h(x^\varepsilon(t - \tau))| \leq e^{-\frac{\nu}{\varepsilon}(t - \tau)} |y^\varepsilon(\tau) - h(\varphi(0))| + |w^\varepsilon(t)|. \quad (4.9)$$

It remains to obtain an estimate for the last term in the above inequality. But by using the  $x$ -equation in (2.1) we have

$$\left| \frac{dx^\varepsilon(t)}{dt} \right| \leq (\alpha + \mu), \forall t \geq 0.$$

Therefore

$$|w^\varepsilon(t)| \leq \int_\tau^t e^{-\frac{\nu}{\varepsilon}(t - s)} \frac{\beta(\mu + \alpha)}{\nu} ds, \forall t \geq \tau,$$

and the estimate follows from (4.9). ■

Next we evaluate  $y^\varepsilon(t) - h(x(t - \tau))$  for  $t \in [0, \tau]$ . Set

$$\|h'\|_{\infty, [0, 1]} := \sup_{x \in [0, 1]} |h'(x)|.$$

**Lemma 4.8** *Let  $(\varphi, y_0)^T \in M$  be given. Then for each  $\delta > 0$  there exists  $\eta := \eta(\delta) > 0$  such that for each  $\varepsilon \in (0, 1)$  and  $t \in [0, \tau]$*

$$|y^\varepsilon(t) - h(\varphi(t - \tau))| \leq e^{-\frac{\nu t}{\varepsilon}} + \|h'\|_{\infty, [0, 1]} \frac{\nu + \beta}{\nu} \left[ 2e^{-\frac{\nu \eta}{\varepsilon}} + \delta \right].$$

*Proof.* Let  $\delta > 0$  be given. Since  $\varphi$  is uniformly continuous on  $[-\tau, 0]$ , there exists  $\eta := \eta(\delta) > 0$  such that for each  $\theta_1, \theta_2 \in [-\tau, 0]$ ,

$$|\theta_1 - \theta_2| < \eta \implies |\varphi(\theta_1) - \varphi(\theta_2)| \leq \delta. \quad (4.10)$$

By using similar arguments as in the proof of Lemma 4.7 we obtain

$$y^\varepsilon(t) = e^{-\frac{1}{\varepsilon} \int_0^t (\nu + \beta \varphi(l - \tau)) dl} y_0 + v^\varepsilon(t), \forall t \in [0, \tau]$$

with  $v^\varepsilon : [0, \tau] \rightarrow \mathbb{R}^+$  is defined by

$$v^\varepsilon(t) := \int_0^t \frac{d}{ds} \left[ e^{-\frac{1}{\varepsilon} \int_s^t (\nu + \beta \varphi(l - \tau)) dl} \right] h(\varphi(s - \tau)) ds, \forall t \in [0, \tau].$$

Therefore we obtain

$$|y^\varepsilon(t) - h(\varphi(t - \tau))| \leq e^{-\frac{\nu t}{\varepsilon}} + |v^\varepsilon(t) - h(\varphi(t - \tau))|, \forall t \in [0, \tau]. \quad (4.11)$$

In order to provide a suitable estimate of the second term of the right hand side of the above inequality let us notice that

$$\begin{aligned}
v^\varepsilon(t) &= \int_0^t \frac{de^{-\frac{1}{\varepsilon} \int_s^t (\nu + \beta \varphi(l - \tau)) dl}}{ds} [h(\varphi(s - \tau)) - h(\varphi(t - \tau))] ds \\
&\quad + \int_0^t \frac{de^{-\frac{1}{\varepsilon} \int_s^t (\nu + \beta \varphi(l - \tau)) dl}}{ds} h(\varphi(t - \tau)) ds \\
&= \int_0^t \frac{de^{-\frac{1}{\varepsilon} \int_s^t (\nu + \beta \varphi(l - \tau)) dl}}{ds} [h(\varphi(s - \tau)) - h(\varphi(t - \tau))] ds \\
&\quad + h(\varphi(t - \tau)) - h(\varphi(t - \tau)) e^{-\frac{1}{\varepsilon} \int_0^t (\nu + \beta \varphi(l - \tau)) dl},
\end{aligned}$$

thus

$$\begin{aligned}
|v^\varepsilon(t) - h(\varphi(t - \tau))| &\leq \int_0^t \left| \frac{de^{-\frac{1}{\varepsilon} \int_s^t (\nu + \beta \varphi(l - \tau)) dl}}{ds} \right| |h(\varphi(s - \tau)) - h(\varphi(t - \tau))| ds \\
&\leq \|h'\|_{\infty, [0, 1]} \frac{\nu + \beta}{\varepsilon} \int_0^t e^{-\frac{\nu}{\varepsilon}(t-s)} |\varphi(s - \tau) - \varphi(t - \tau)| ds \\
&\leq \|h'\|_{\infty, [0, 1]} \frac{\nu + \beta}{\varepsilon} \left[ \int_{t-\eta}^t e^{-\frac{\nu}{\varepsilon}(t-s)} |\varphi(s - \tau) - \varphi(t - \tau)| ds \right. \\
&\quad \left. + \int_0^{t-\eta} e^{-\frac{\nu}{\varepsilon}(t-s)} |\varphi(s - \tau) - \varphi(t - \tau)| ds \right] \\
&\leq 2 \|h'\|_{\infty, [0, 1]} \frac{\nu + \beta}{\varepsilon} \int_0^{t-\eta} e^{-\frac{\nu}{\varepsilon}(t-s)} ds \\
&\quad + \|h'\|_{\infty, [0, 1]} \frac{\nu + \beta}{\varepsilon} \int_0^\eta e^{-\frac{\nu}{\varepsilon} l} |\varphi(t - \tau - l) - \varphi(t - \tau)| dl.
\end{aligned}$$

Due to (4.10) one obtains

$$\int_0^\eta e^{-\frac{\nu}{\varepsilon} l} |\varphi(t - \tau - l) - \varphi(t - \tau)| dl \leq \int_0^\eta e^{-\frac{\nu}{\varepsilon} l} \delta dl, \quad \forall t \in [0, \tau],$$

that implies that for all  $t \in [0, \tau]$ ,

$$|v^\varepsilon(t) - h(\varphi(t - \tau))| \leq \|h'\|_{\infty, [0, 1]} \frac{\nu + \beta}{\varepsilon} \left[ 2 \int_0^{t-\eta} e^{-\frac{\nu}{\varepsilon}(t-s)} ds + \delta \int_0^\eta e^{-\frac{\nu}{\varepsilon} l} dl \right],$$

that completes the proof.  $\blacksquare$

We are now able to complete the proof of Theorem 2.5 by investigating the limit behavior of  $y^\varepsilon$  as  $\varepsilon \rightarrow 0$ .

**Theorem 4.9 (Almost global uniform convergence)** *Let  $\begin{pmatrix} y_0 \\ \varphi \end{pmatrix} \in M$  be given such that  $\varphi \neq 0_C$ . Then the following holds true for each  $K > 0$*

$$\lim_{\varepsilon \rightarrow 0} \sup_{t \geq K\varepsilon |\ln \varepsilon|} |y^\varepsilon(t) - h(x(t - \tau))| = 0.$$

*Proof.* Let  $K > 0$  be given. Let  $\delta > 0$  be given. Due to Lemma 4.8 that there exists  $\eta > 0$  such that for all  $\varepsilon > 0$  small enough and  $t \in [K\varepsilon |\ln \varepsilon|, \tau]$  one has

$$|y^\varepsilon(t) - h(\varphi(t - \tau))| \leq e^{-K\nu |\ln \varepsilon|} + \|h'\|_{\infty, [0, 1]} \frac{\nu + \beta}{\nu} \left[ 2e^{-\frac{\nu\eta}{\varepsilon}} + \delta \right]. \quad (4.12)$$

On the other hand from Lemma 4.7 we have

$$|y^\varepsilon(t) - h(x^\varepsilon(t - \tau))| \leq \kappa\varepsilon + e^{-\frac{\nu}{\varepsilon}(t-\tau)} |y^\varepsilon(\tau) - h(\varphi(0))|, \quad \forall t \geq \tau.$$

Now using (4.12) with  $t = \tau$  to estimate  $|y^\varepsilon(\tau) - h(\varphi(0))|$ , one obtains that for all  $\varepsilon > 0$  small enough and each  $t \geq \varepsilon|\ln \varepsilon|$

$$|y^\varepsilon(t) - h(x^\varepsilon(t - \tau))| \leq \kappa\varepsilon + e^{-K\nu|\ln \varepsilon|} + \|h'\|_{\infty, [0,1]} \frac{\nu + \beta}{\nu} \left[ 2e^{-\frac{\nu\eta}{\varepsilon}} + \delta \right].$$

As a consequence one obtains

$$\limsup_{\varepsilon \rightarrow 0} \sup_{t \geq K\varepsilon|\ln \varepsilon|} |y^\varepsilon(t) - h(x^\varepsilon(t - \tau))| \leq \|h'\|_{\infty, [0,1]} \frac{\nu + \beta}{\nu} \delta, \quad \forall \delta > 0$$

and the result follows. ■

## 5 Heteroclinic orbits

The aim of this section is to prove Theorem 2.5. To be more specific, in this section we consider the case where  $\varphi \equiv 0_C$  and  $y_0 \in (0, 1]$  and we are interested by the convergence of  $x^\varepsilon$  whenever  $R_0 > 1$ . In such a case, due to Lemma 3.2-(iii), the uniform convergence on the half line toward the solution of the reduced problem cannot hold true. Instead of that we will prove the convergence to the unique heteroclinic of the reduced system. We conclude the paper with a convergence result which achieve the proof of Theorem 2.5.

### 5.1 Existence and uniqueness of heteroclinic orbits for the reduced system

Our first result deals with the existence of heteroclinic orbits for the reduced system and the result reads as follows:

**Proposition 5.1** *Assume that  $R_0 > 1$ . Then there exists an heteroclinic orbit  $x$  of the reduced system (2.4) that satisfies*

$$0 < x(t) \leq \bar{x}, \quad \forall t \in \mathbb{R}; \quad \lim_{t \rightarrow -\infty} x(t) = 0 \quad \text{and} \quad \lim_{t \rightarrow +\infty} x(t) = \bar{x}.$$

*Proof.* Let  $\varphi = 0_C$  and  $y_0 \in (0, 1]$  be given. Due to Lemma 3.2 (iii) we know that for each  $\varepsilon > 0$ ,  $x^\varepsilon(t) \rightarrow \bar{x}$  as  $t \rightarrow \infty$ . Next since  $x^\varepsilon(0) = \varphi(0) = 0$ , for each  $\varepsilon > 0$  there exists  $t_\varepsilon > 0$  such that  $x^\varepsilon(t_\varepsilon) = \frac{\bar{x}}{2}$ . Moreover due to Lemma 4.1 the family of maps  $t \mapsto x_t^\varepsilon$  converges locally uniformly to the equilibrium  $0_C$ , so that  $t_\varepsilon \rightarrow +\infty$  as  $\varepsilon \rightarrow 0$ . Hence one can define the family of shifted maps

$$\hat{x}_t^\varepsilon = x_{t+t_\varepsilon}^\varepsilon \quad \text{and} \quad \hat{y}^\varepsilon(t) = y^\varepsilon(t + t_\varepsilon), \quad \forall t \geq -t_\varepsilon.$$

Similarly to proof of Lemma 4.1, there exists a sequence  $\{\varepsilon_n\}_{n \geq 0} \subset (0, 1]$  and tending to 0 as  $n \rightarrow \infty$  such that  $\hat{x}^{\varepsilon_n} \rightarrow x^0$  locally uniformly and where  $x^0$  is an entire solution of (2.4) such that

$$x^\infty(0) = \frac{\bar{x}}{2}, \quad 0 \leq x^\infty(t) \leq 1, \quad \forall t \in \mathbb{R}.$$

As a consequence of the first constraint,  $x^\infty$  cannot be identically equal to an equilibrium point of (2.4), namely  $0_C$  or  $\bar{x}$ . Then Lemma 3.3 applies and completes the proof of the result.  $\blacksquare$

The next result of this section is related to the uniqueness of the heteroclinic orbit constructed in Proposition 5.1. Our precise result reads as follows:

**Theorem 5.2** *Assume that  $R_0 > 1$ . The reduced system (2.4) has a unique (up to time shift) heteroclinic orbit  $x$  such that*

$$\lim_{t \rightarrow -\infty} x(t) = 0 \quad \text{and} \quad \lim_{t \rightarrow +\infty} x(t) = \bar{x}.$$

The proof of this result will be related to Ikehara's theorem (see Carr and Chmaj [8] and the references cited therein) and Laplace transform (see Widder [27]). Our proof is inspired by the one by Carr and Chmaj [8] and Yu and Mei [28]. Before proving the above result, several lemmas are necessary. The uniqueness of this orbit is related to a suitable description of its behavior as  $t \rightarrow -\infty$ , when the function is approaching  $0_C$ . We will therefore consider the linearized equation associated to (2.4) around  $0_C$ , namely

$$\begin{cases} \frac{du(t)}{dt} = -\mu u(t) + \alpha h'(0) u(t - \tau), \\ u_0 = \varphi \in C. \end{cases} \quad (5.1)$$

The characteristic equation of the above delay differential equation is

$$\Delta(\lambda) := \lambda + \mu - \frac{\alpha\beta}{\nu} e^{-\lambda\tau}. \quad (5.2)$$

Then our first result is related to some properties on the location of the roots of the characteristic function  $\Delta$ .

**Lemma 5.3** *Assume that  $R_0 > 1$ . Then the following properties are satisfied*

(i) *There exists a unique  $\lambda_0 > 0$  such that  $\Delta(\lambda_0) = 0$  and*

$$\Delta'(\lambda_0) \neq 0 \quad \text{and} \quad \Delta(\lambda) < 0, \quad \forall \lambda \in [0, \lambda_0).$$

(ii) *For all  $z \in \mathbb{C}$  we have*

$$\Delta(z) = 0 \quad \text{and} \quad \operatorname{Re}(z) = \lambda_0 \iff z = \lambda_0.$$



*Proof.* The proof (i) is obvious and thus omitted. Now let us prove (ii). Let  $z \in \mathbb{C}$  be given such that  $\Delta(z) = 0$  and  $Re(z) = \lambda_0$ . Then we have  $\Delta(\lambda_0 + iIm(z)) = 0$  which implies that

$$\begin{cases} \lambda_0 + \mu = \frac{\alpha\beta}{\nu} e^{-\tau\lambda_0} \cos(\tau Im(z)), \\ Im(z) = -\frac{\alpha\beta}{\nu} e^{-\tau\lambda_0} \sin(\tau Im(z)). \end{cases} \quad (5.3)$$

Since  $\Delta(\lambda_0) = 0$ , namely  $\lambda_0 + \mu = \frac{\alpha\beta}{\nu} e^{-\tau\lambda_0}$ , we infer from (5.3) that

$$\frac{\alpha\beta}{\nu} e^{-\tau\lambda_0} = \frac{\alpha\beta}{\nu} e^{-\tau\lambda_0} \cos(\tau Im(z)) \implies \cos(\tau Im(z)) = 1,$$

thus

$$\sin(\tau Im(z)) = 0.$$

The result follows by using the second equation of (5.3).  $\blacksquare$

In the sequel, we always assume that  $R_0 > 1$  and let  $x$  be a given heteroclinic orbit of the reduced system (2.4) such that

$$0 < x(t) < 1 \text{ and } \lim_{t \rightarrow -\infty} x(t) = 0 \text{ and } \lim_{t \rightarrow \infty} x(t) = \bar{x}.$$

The aim of the next lemma is to prove that the convergence to 0 as  $t \rightarrow -\infty$  is exponential. In the sequel we will prove that we have in fact  $x(t) = O(e^{\lambda_0 t})$  as  $t \rightarrow -\infty$  where  $\lambda_0$  is described in Lemma 5.3.

**Lemma 5.4** *Assume that  $R_0 > 1$ . There exists  $\rho > 0$  such that  $x(t) = O(e^{\rho t})$  as  $t \rightarrow -\infty$ .*

The proof of this result is split into three steps. In step 1, we show that  $\int_{-\infty}^t x(s) ds < +\infty$  for all  $t \in \mathbb{R}$ . Step 2 is devoted to show that there exists  $\rho > 0$  such that

$$\sup_{t \leq 0} e^{-\rho t} \int_{-\infty}^t x(s) ds < +\infty.$$

Finally step 3 completes the proof of the lemma.

*Proof.* Note that

$$\|h'\|_{\infty, [0,1]} = h'(0) = \frac{\beta}{\nu} > 0. \quad (5.4)$$

Since  $R_0 > 1$  we can find  $\eta \in (0, 1)$  such that

$$\frac{\alpha\beta}{\nu} (1 - \eta) > \mu. \quad (5.5)$$

Moreover due to (5.4), we can find  $\delta > 0$  small enough such that

$$0 < x < \delta \implies h(x) > \frac{\beta}{\nu} (1 - \eta) x, \quad (5.6)$$

and

$$\frac{\alpha\beta}{\nu} (1 - \eta) (1 - \delta) > \mu. \quad (5.7)$$

**Step 1:** Let us prove that for each  $t \in \mathbb{R}$ ,  $\int_{-\infty}^t x(s) ds < +\infty$ . Integrating (2.4) from  $t_0$  to  $t$  yields

$$x(t) - x(t_0) = -\mu \int_{t_0}^t x(s) ds + \alpha \int_{t_0}^t h(x(s-\tau))(1-x(s)) ds. \quad (5.8)$$

Recalling that  $x(t) \rightarrow 0$  as  $t \rightarrow -\infty$ , there exists  $T > 0$  large enough such that for all  $t \leq -T$

$$0 < x(t) < \delta,$$

where  $\delta > 0$  is defined in (5.6). Hence we obtain

$$h(x(s-\tau)) \geq \frac{\beta}{\nu} (1-\eta) x(s-\tau), \quad \forall s \leq -T, \quad (5.9)$$

and by combining (5.8) and (5.9) we obtain for all  $t_0 \leq t \leq -T$ , that

$$x(t) - x(t_0) \geq -\mu \int_{t_0}^t x(s) ds + \int_{t_0}^t \frac{\alpha\beta}{\nu} (1-\eta) x(s-\tau) (1-x(s)) ds.$$

But due to Lemma 3.3, we have

$$0 < x(t) \leq \bar{x}, \quad \forall t \in \mathbb{R},$$

therefore for all  $t_0 \leq t \leq -T$ ,

$$x(t) - x(t_0) \geq -\mu \int_{t_0}^t x(s) ds + \int_{t_0}^t \frac{\alpha\beta}{\nu} (1-\eta) (1-\delta) x(s-\tau) ds,$$

thus

$$x(t) - x(t_0) \geq A \int_{t_0}^t [x(s-\tau) - x(s)] ds + B \int_{t_0}^t x(s) ds, \quad (5.10)$$

where

$$A := \frac{\alpha\beta}{\nu} (1-\eta) (1-\delta) > 0 \text{ and } B := \left[ \frac{\alpha\beta}{\nu} (1-\eta) (1-\delta) - \mu \right] > 0.$$

Let us notice that

$$\int_{t_0}^t [x(s-\tau) - x(s)] ds = - \int_{t_0}^t \int_{-\tau}^0 \frac{dx(s+l)}{dl} dl ds = - \int_{-\tau}^0 [x(l+t) - x(l+t_0)] dl.$$

Due to the above reformulation and  $B > 0$ , recalling that  $x(t) \rightarrow 0$  as  $t \rightarrow -\infty$ , allow us to let  $t_0 \rightarrow -\infty$  into (5.10) yielding that for all  $t \leq -T$ ,

$$x(t) + A \int_{-\tau}^0 x(l+t) dl \geq B \int_{-\infty}^t x(s) ds, \quad (5.11)$$

that completes the proof of Step 1.

**Step 2:** Let us prove that there exists  $\rho > 0$  and some constant  $\kappa > 0$  such that  $e^{-\rho t} \int_{-\infty}^t x(s) ds \leq \kappa$ , for all  $t \in (-\infty, 0]$ . To do so let us define  $X : \mathbb{R} \rightarrow \mathbb{R}^+$  by

$$X(t) := \int_{-\infty}^t x(r) dr.$$

Note that due to (5.11),  $X \in L^1(-\infty, -T)$ . Since  $X$  is non-decreasing, one has for each  $t \leq -T$

$$\int_{-\infty}^t \int_{-\tau}^0 x(l+s) ds dl = \int_{-\tau}^0 X(t+l) dl \leq \tau X(t),$$

therefore by integrating (5.11) over  $(-\infty, t]$  we obtain

$$B \int_{-\infty}^t X(s) ds \leq (1 + \tau A) X(t), \quad \forall t \leq -T. \quad (5.12)$$

Now let  $t_1 > 0$  be given large enough such that

$$\rho := \frac{1}{t_1} \ln \left( \frac{Bt_1}{1 + \tau A} \right) > 0.$$

Then note that since  $X$  is increasing then

$$X(t - t_1) \leq X(t + s), \quad \forall s \in [-t_1, 0], \quad \forall t \in (-\infty, -T].$$

This implies that for each  $t \leq -T$

$$X(t - t_1) \leq \frac{1}{t_1} \int_{t-t_1}^t X(s) ds, \quad (5.13)$$

and this latter inequality combined together with (5.12) provides that for all  $t \leq -T$ :

$$X(t - t_1) \leq \frac{1}{t_1} \int_{-\infty}^t X(s) ds \leq \frac{1 + \tau A}{Bt_1} X(t).$$

Due to the definition of  $\rho$ , one obtains that

$$\sup_{t \leq -T} e^{-\rho t} X(t) < \infty,$$

that completes the proof of Step 2.

**Step 3:** This step will conclude the proof of Lemma 5.4. Integrating (2.4) over  $(-\infty, t)$  for some given  $t \leq 0$  yields to

$$x(t) \leq \int_{-\infty}^t \alpha h(x(s - \tau))(1 - x(s)) ds \leq \int_{-\infty}^t \alpha h(x(s - \tau)) ds \leq \int_{-\infty}^t \frac{\alpha \beta}{\nu} x(s - \tau) ds,$$

Step 2 applies and provides that the right hand side of this inequality is bounded by  $Ke^{\rho t}$  on  $(-\infty, 0]$  for some constant  $K > 0$  and the result follows.  $\blacksquare$

Define the *Laplace transform* of  $u$

$$\mathcal{L}(u)(\lambda) := \int_0^{+\infty} u(t) e^{-\lambda t} dt$$

whenever the integral exists. We will say that the Laplace transform *converges* if the limit

$$\lim_{\tau \rightarrow +\infty} \int_0^\tau e^{-\lambda t} u(t) dt$$

exists, and we will say that the Laplace transform *diverges* otherwise.

For convenience let us recall the following theorem which can be found in Carr and Chmaj [8].

**Theorem 5.5 (Ikehara's)** *Let  $u : [0, +\infty) \rightarrow [0, +\infty)$  a positive decreasing locally integrable function. Assume that there exists a function  $H$  which is analytic in the strip  $\Sigma := \{\lambda \in \mathbb{C} : -\zeta \leq \operatorname{Re}(\lambda) < 0\}$  and there exists an integer  $k > -1$  such that*

$$\mathcal{L}(u)(\lambda) := \frac{H(\lambda)}{(\lambda + \zeta)^{k+1}}, \forall \lambda \in \Sigma.$$

Then

$$\lim_{t \rightarrow +\infty} \frac{u(t)}{t^k e^{-\zeta t}} \text{ exists}$$

and this limit is equal to

$$\frac{H(-\zeta)}{\Gamma(\zeta + 1)}$$

where  $\Gamma(x)$  is the gamma function.

Before recalling Widder's theorem, let us recall that for a function  $u : [0, +\infty) \rightarrow \mathbb{R}$ , we call *abscissa of convergence* of  $u$ ,

$$\operatorname{abs}(u) := \inf \{ \operatorname{Re}(\lambda) : \text{there exists } \lambda \in \mathbb{C} \text{ for which } \mathcal{L}(u)(\lambda) \text{ exists} \}.$$

Recall also that the *abscissa of absolute convergence* of  $u$  is  $\operatorname{abs}(|u|)$ .

We refer to the proof of Proposition 1.4.1 p. 28 in Arendt et al. [2] of the following lemma.

**Lemma 5.6** *Let  $u : [0, +\infty) \rightarrow [0, +\infty)$  be a locally integrable map. Assume that  $\mathcal{L}(u)(\lambda_0)$  converges for some complex number  $\lambda_0 \in \mathbb{C}$ . Then  $\mathcal{L}(u)(\lambda)$  converges for each  $\lambda \in \mathbb{C}$  with  $\operatorname{Re}(\lambda) > \operatorname{Re}(\lambda_0)$ .*

**Remark 5.7** *By using this lemma we deduce that the Laplace transform of  $u$  converges for each  $\lambda \in \mathbb{C}$  with  $\operatorname{Re}(\lambda) > \operatorname{abs}(u)$  and diverges for each  $\lambda \in \mathbb{C}$  with  $\operatorname{Re}(\lambda) < \operatorname{abs}(u)$ . This last property sometimes serves as a definition for the abscissa of convergence of  $u$ .*

The following Theorem is due to Widder [27, p.58] (see also Arendt et al. [2, Theorem 1.5.3. p. 34]).

**Theorem 5.8 (Widder's)** *Let  $u : [0, +\infty) \rightarrow [0, +\infty)$  be a non-negative and locally integrable map. Assume that  $\text{abs}(u) < +\infty$ . Then  $\mathcal{L}(u)(\lambda)$  is holomorphic in  $\{\lambda \in \mathbb{C} : \text{Re}(\lambda) > \text{abs}(u)\}$ . If in addition  $\text{abs}(u) > -\infty$ , then  $\mathcal{L}(u)(\lambda)$  has a singularity at  $\text{abs}(u)$ .*

Now let us set

$$v(t) := x(-t), \quad \forall t \in \mathbb{R},$$

that is an entire solution of the equation

$$\frac{dv(t)}{dt} = \mu v(t) - \alpha h(v(t+\tau))(1-v(t)), \quad t \in \mathbb{R}. \quad (5.14)$$

Due to Lemma 5.4, we have

$$v(t) = O(e^{-\rho t}) \quad \text{as } t \rightarrow \infty.$$

Therefore the Laplace transform  $\mathcal{L}(v)(\lambda)$  converges for each  $\lambda \in \mathbb{C}$  with  $\text{Re}(\lambda) > -\rho$ , and we must have

$$\text{abs}(v) \leq -\rho.$$

By applying the Laplace transform to (5.14) yields to

$$\left(\lambda - \mu + \frac{\alpha\beta}{\nu}e^{\lambda\tau}\right) \mathcal{L}(v)(\lambda) = v(0) + \frac{\alpha\beta}{\nu}e^{\lambda\tau} \int_0^\tau v(t) e^{-\lambda t} dt + \mathcal{L}(R)(\lambda),$$

where

$$R(t) := \frac{\alpha\beta}{\nu}v(t+\tau) - \alpha h(v(t+\tau))(1-v(t)).$$

Recalling the definition of  $\Delta$  in (5.2), the latter equation rewrites as

$$-\Delta(-\lambda) \mathcal{L}(v)(\lambda) = v(0) + \frac{\alpha\beta}{\nu}e^{\lambda\tau} \int_0^\tau v(t) e^{-\lambda t} dt + \mathcal{L}(R)(\lambda). \quad (5.15)$$

**Remark 5.9** *Note that for all  $t \in \mathbb{R}$*

$$\begin{aligned} \alpha h(v(t+\tau))(1-v(t)) &= \alpha \frac{\beta v(t+\tau)}{\beta v(t+\tau) + \nu} (1-v(t)) \\ &= \frac{\alpha\beta v(t+\tau)}{\nu} \frac{\nu}{\beta v(t+\tau) + \nu} (1-v(t)) \\ &\leq \frac{\alpha\beta v(t+\tau)}{\nu} (1-v(t)), \end{aligned}$$

thus for all  $t \in \mathbb{R}$

$$R(t) \geq \frac{\alpha\beta}{\nu}v(t+\tau) - \frac{\alpha\beta v(t+\tau)}{\nu} (1-v(t)) \geq \frac{\alpha\beta}{\nu}v(t+\tau)v(t) > 0,$$

and we deduce that

$$v(0) + \frac{\alpha\beta}{\nu}e^{\lambda\tau} \int_0^\tau v(t) e^{-\lambda t} dt + \int_0^{+\infty} R(t) e^{-\lambda t} dt > 0,$$

whenever  $\lambda \in \mathbb{R}$  and  $\mathcal{L}(v)(\lambda) < +\infty$ .

In the next lemma we investigate to the analyticity of  $\mathcal{L}(v)(\lambda)$ .

**Lemma 5.10** *Let  $\lambda_0 \in \mathbb{R}$  be the real number defined in Lemma 5.3. Then the Laplace transform  $\mathcal{L}(v)(\lambda)$  is well defined and analytic in the strip  $\{\lambda \in \mathbb{C} : \text{Re}(\lambda) > -\lambda_0\}$ . Moreover we have*

$$\lim_{\lambda(>-\lambda_0) \rightarrow -\lambda_0} \mathcal{L}(v)(\lambda) = +\infty,$$

while

$$\text{abs}(R) < -\lambda_0.$$

*Proof.* Let us first prove that

$$\lim_{\lambda(>-\lambda_0^+) \rightarrow -\lambda_0^+} \mathcal{L}(v)(\lambda) = +\infty.$$

Let us assume that

$$\lim_{\lambda(>-\lambda_0^+) \rightarrow -\lambda_0^+} \mathcal{L}(v)(\lambda) < +\infty. \quad (5.16)$$

Next note that since  $v(t) > 0$  for all  $t \in \mathbb{R}$ , we have for each  $\lambda_1, \lambda_2 \in \mathbb{R}$

$$\lambda_1 \geq \lambda_2 \implies \mathcal{L}(v)(\lambda_1) \leq \mathcal{L}(v)(\lambda_2).$$

Therefore (5.16) implies that

$$\mathcal{L}(v)(\lambda) < +\infty, \quad \forall \lambda \in \mathbb{R} \text{ with } \lambda > -\lambda_0. \quad (5.17)$$

But by using Fatou's Lemma we obtain

$$\mathcal{L}(v)(-\lambda_0) = \int_0^{+\infty} \lim_{\lambda(>-\lambda_0) \rightarrow -\lambda_0} e^{\lambda t} v(t) dt \leq \lim_{\lambda(>-\lambda_0) \rightarrow -\lambda_0} \int_0^{+\infty} e^{\lambda t} v(t) dt < +\infty.$$

We conclude from (5.17) that

$$\mathcal{L}(v)(\lambda) < +\infty, \quad \forall \lambda \in [-\lambda_0, +\infty).$$

Now by using (5.15), it follows that

$$0 < \mathcal{L}(R)(\lambda) < +\infty, \quad \forall \lambda \in [-\lambda_0, +\infty),$$

and since  $\Delta(\lambda_0) = 0$  by taking the limit when  $\lambda$  goes to  $-\lambda_0^+$  (with  $\lambda \in \mathbb{R}$ ) into (5.15) we obtain

$$\lim_{\lambda(>-\lambda_0) \rightarrow -\lambda_0} \mathcal{L}(R)(\lambda) = \mathcal{L}(R)(-\lambda_0) = -v(0) - \frac{\alpha\beta}{\nu} e^{-\lambda_0\tau} \int_0^\tau v(t) e^{\lambda_0 t} dt < 0,$$

that is a contradiction with the fact that  $R(t) > 0$  for each  $t \geq 0$  (see Remark 5.9).

The contradiction proves that  $\mathcal{L}(v)$  has a singularity at  $-\lambda_0$  and

$$\lim_{\lambda(>-\lambda_0^+) \rightarrow -\lambda_0^+} \mathcal{L}(v)(\lambda) = +\infty.$$

As a consequence of Lemma 5.6, we deduce that

$$-\lambda_0 \leq \text{abs}(v) \leq -\rho < 0.$$

Next we will prove that  $\mathcal{L}(v)$  is analytic on the strip  $\{\lambda \in \mathbb{C} : -\lambda_0 < \text{Re}(\lambda)\}$ . Due to Theorem 5.8 it is sufficient to show that

$$\text{abs}(v) = -\lambda_0.$$

Assume by contradiction that

$$-\lambda_0 < \text{abs}(v).$$

Since  $\lambda^* := \text{abs}(v) < 0$ , we have

$$-\lambda_0 < \lambda^* < 0,$$

therefore by Lemma 5.3-(i) we obtain

$$\Delta(-\lambda^*) < 0. \tag{5.18}$$

Let  $\eta \in (0, \rho)$  (where  $\rho > 0$  is defined above). We also have for each  $t \in \mathbb{R}$

$$\begin{aligned} 0 &< R(t) = \frac{\alpha\beta}{\nu}v(t+\tau) - \alpha\frac{\beta v(t+\tau)}{\beta v(t+\tau) + \nu}(1-v(t)) \\ &= \frac{\alpha\beta}{\nu}v(t+\tau) \left[ 1 - \nu\frac{(1-v(t))}{\beta v(t+\tau) + \nu} \right] \\ &= \frac{\alpha\beta}{\nu}v(t+\tau) \left[ \frac{\beta v(t+\tau) + \nu v(t)}{\beta v(t+\tau) + \nu} \right] \\ &\leq \frac{\alpha\beta}{\nu}v(t+\tau)v(t). \end{aligned}$$

Hence

$$\begin{aligned} \int_0^{+\infty} R(t) e^{-(\lambda^* - \eta/2)t} dt &\leq \frac{\alpha\beta}{\nu} \int_0^{+\infty} v(t+\tau)v(t) e^{-(\lambda^* - \eta/2)t} dt \\ &\leq \frac{\alpha\beta}{\nu} \int_0^{+\infty} v(t) e^{-(\lambda^* + \eta/2)t} dt \sup_{t \geq 0} e^{\eta t} v(t+\tau). \end{aligned}$$

Recalling Lemma 5.4 and the definition of  $v$ , due to the choice of  $\eta \in (0, \rho)$  one has

$$\sup_{t \geq 0} e^{\eta t} v(t+\tau) < +\infty,$$

while since  $\text{abs}(v) + \eta/2 > \text{abs}(v)$  we obtain that

$$\int_0^{+\infty} v(t) e^{-(\lambda^* + \eta/2)t} dt < \infty$$

so by (5.15)

$$\int_0^{+\infty} R(t) e^{-(\lambda^* - \eta/2)t} dt < \infty.$$

Thus

$$abs(R) \leq abs(v) - \eta/2, \quad \forall \eta \in (0, \rho).$$

Moreover since  $abs(R) < abs(v)$  and since  $-\lambda_0 < abs(v)$  there exists  $\kappa > 0$  small enough such that the map

$$\lambda \mapsto \frac{1}{-\Delta(\lambda)} \left[ v(0) + \frac{\alpha\beta}{\nu} e^{\lambda\tau} \int_0^\tau v(t) e^{-\lambda t} dt + \mathcal{L}(R)(\lambda) \right],$$

is analytic on the strip  $\{\lambda \in \mathbb{C} : Re(\lambda) > abs(v) - \kappa\}$  and it is an extension of  $\mathcal{L}(v)$ , a contradiction with Widder's theorem, namely Theorem 5.8. As a consequence  $abs(v) = -\lambda_0$ . To complete the proof of the Lemma let us notice that using the same arguments as before, one has  $abs(R) < -\lambda_0 (= abs(v))$  and the result follows.  $\blacksquare$

Before proving Theorem 5.2 we need to derive the precise behavior of  $x(t)$  when  $t$  goes to  $-\infty$ . This will be achieved in the next lemma. Before let us introduce, due to Lemma 5.10 the analytic function  $H$  acting from the strip  $\{\lambda \in \mathbb{C} : Re(\lambda) > -\lambda_0\}$  into  $\mathbb{C}$  defined by

$$H(\lambda) := (\lambda + \lambda_0) \mathcal{L}(v)(\lambda) \quad (5.19)$$

or equivalently

$$H(\lambda) := \frac{(\lambda + \lambda_0)}{-\Delta(-\lambda)} \left[ v(0) + \frac{\alpha\beta}{\nu} e^{\lambda\tau} \int_0^\tau v(t) e^{-\lambda t} dt + \mathcal{L}(R)(\lambda) \right]. \quad (5.20)$$

Using this function, our next lemma reads as

**Lemma 5.11** *The following holds true*

$$\lim_{t \rightarrow -\infty} \frac{x(t)}{e^{\lambda_0 t}} = \frac{H(-\lambda_0 - \mu)}{\Gamma(1 + \lambda_0 + \mu)} > 0, \quad (5.21)$$

with  $\lambda_0$  defined in Lemma 5.3.

*Proof.* Since we have defined  $v(t) = x(-t)$  for all  $t \in \mathbb{R}$ , (5.21) is equivalent to

$$\lim_{t \rightarrow +\infty} \frac{v(t)}{e^{-\lambda_0 t}} = \frac{H(-\lambda_0 - \mu)}{\Gamma(1 + \lambda_0 + \mu)}.$$

But equation (5.14) implies that

$$\frac{d[e^{-\mu t} v(t)]}{dt} = -e^{-\mu t} \alpha h(v(t + \tau))(1 - v(t)) \leq 0, \quad \forall t \in \mathbb{R},$$

therefore the map  $t \in [0, +\infty) \rightarrow e^{-\mu t} v(t)$  is a decreasing. Set

$$\hat{v}(t) := e^{-\mu t} v(t), \quad \forall t \geq 0.$$



Next notice that for each  $\lambda \in \left\{ \hat{\lambda} \in \mathbb{C} : -\lambda_0 - \mu \leq \operatorname{Re}(\hat{\lambda}) < 0 \right\}$  one has

$$\int_0^{+\infty} \hat{v}(t) e^{-\lambda t} dt = \frac{H(\lambda + \mu)}{\lambda + \lambda_0 + \mu}.$$

Therefore since  $\hat{v}$  is positive and decreasing, and Ikehara's theorem implies

$$\lim_{t \rightarrow +\infty} \frac{\hat{v}(t)}{e^{-(\lambda_0 + \mu)t}} = \frac{H(-\lambda_0 - \mu)}{\Gamma(1 + \lambda_0 + \mu)} \Leftrightarrow \lim_{t \rightarrow -\infty} \frac{v(t)}{e^{\lambda_0 t}} = \frac{H(-\lambda_0 - \mu)}{\Gamma(1 + \lambda_0 + \mu)}.$$

That completes the proof. ■

**Corollary 5.12** *Function  $x$  is increasing on  $\mathbb{R}$ .*

*Proof.* According to Lemma 5.11, there exists  $\alpha_x > 0$  such that  $e^{-\lambda_0 t} x(t) \rightarrow \alpha_x$  as  $t \rightarrow -\infty$ . Now from (2.4) one obtains that

$$\lim_{t \rightarrow -\infty} e^{-\lambda_0 t} x'(t) = \alpha_x \left[ -\mu + \frac{\alpha\beta}{\nu} e^{-\lambda_0 \tau} \right] = \alpha_x \lambda_0 > 0.$$

The result follows from the results of Smith [24]. ■

We now have all the necessary ingredient to complete the proof of Theorem 5.2.

*Proof of Theorem 5.2.* Let  $x$  and  $y$  be two heteroclinic orbits of the reduced system (2.4). From Lemma Lemma 5.11 there exists  $\alpha_x > 0$  and  $\alpha_y > 0$  such that

$$\lim_{t \rightarrow -\infty} e^{-\lambda_0 t} x(t) = \alpha_x \text{ and } \lim_{t \rightarrow -\infty} e^{-\lambda_0 t} y(t) = \alpha_y.$$

Hence there exists  $h \in \mathbb{R}$  such that

$$\lim_{t \rightarrow -\infty} e^{-\lambda_0 t} x(t) = \lim_{t \rightarrow -\infty} e^{-\lambda_0 t} y(t+h).$$

Up to change  $y(t)$  by  $y(t+h)$ , one may assume that  $h = 0$ , that is

$$\lim_{t \rightarrow -\infty} e^{-\lambda_0 t} x(t) = \lim_{t \rightarrow -\infty} e^{-\lambda_0 t} y(t).$$

Next let us define

$$w(t) := \frac{x(t) - y(t)}{e^{\lambda_0 t}}, \quad \forall t \in \mathbb{R}.$$

We aim to show that  $w(t) \equiv 0$ , so that  $x(t) \equiv y(t)$ . To do so note that Lemma 5.11 ensures that  $w(t) \rightarrow 0$  as  $t \rightarrow -\infty$  and one can also notice that since  $x$  and  $y$  are bounded, one has  $w(t) \rightarrow 0$  as  $t \rightarrow \infty$ . We conclude that  $w$  is bounded on  $\mathbb{R}$ . Assume by contradiction that  $w(t) \not\equiv 0$ . Then, replacing eventually  $x - y$  by  $y - x$ , we can assume, without loss of generality, there exists  $t_0 \in \mathbb{R}$  such that

$$w(t_0) = \sup_{t \in \mathbb{R}} |w(t)| > 0. \tag{5.22}$$

We claim that  $w(t_0) = w(t_0 - \tau)$ . Indeed since  $w(t_0)$  is a maximum, we have

$$\begin{aligned} \frac{dw(t_0)}{dt} &= 0 = -(\lambda_0 + \mu)w(t_0) \\ &\quad + e^{-\lambda_0 t_0} [\lambda_0 \alpha h(x(t_0 - \tau))(1 - x(t_0)) - \alpha h(y(t_0 - \tau))(1 - y(t_0))], \end{aligned}$$

thus

$$\begin{aligned} (\lambda_0 + \mu)w(t_0) &= \alpha \frac{h(x(t_0 - \tau)) - h(y(t_0 - \tau))}{e^{\lambda_0 t_0}} (1 - x(t_0)) - \alpha w(t_0) h(y(t_0 - \tau)) \\ &\leq \alpha \frac{h(x(t_0 - \tau)) - h(y(t_0 - \tau))}{e^{\lambda_0 t}} \\ &\leq \alpha \int_0^1 h'(sx(t_0 - \tau) + (1 - s)y(t_0 - \tau)) ds w(t_0 - \tau) \\ &\leq \alpha h'(0) w(t_0 - \tau) \\ &\leq \frac{\alpha \beta}{\nu} e^{-\lambda_0 \tau} w(t_0 - \tau). \end{aligned}$$

Here recalling that  $\lambda_0 + \mu = \frac{\alpha \beta}{\nu} e^{-\lambda_0 \tau}$  it follows that

$$w(t_0) \leq w(t_0 - \tau).$$

Therefore since  $w(t_0)$  is a maximum point we also have  $w(t_0) \geq w(t_0 - \tau)$  so that  $w(t_0) = w(t_0 - \tau)$ . By induction one concludes  $w(t_0) = w(t_0 - n\tau)$  for all  $n \in \mathbb{N}$  which implies that

$$w(t_0) = \lim_{n \rightarrow +\infty} w(t_0 - n\tau) = \lim_{t \rightarrow -\infty} w(t) = 0.$$

That contradict the fact that  $w(t_0) > 0$ . Therefore  $w(t) \equiv 0$  and the result follows.  $\blacksquare$

## 5.2 Convergence to the heteroclinic orbits

In this subsection we study the convergence of  $x^\varepsilon$  whenever the initial conditions  $\varphi = 0_C$  and  $y_0 \neq 0$  and we complete the convergence part stated in Theorem 2.5. In the sequel we denote  $x^\infty$  the unique heteroclinic orbit of the reduced system provided by Theorem 5.2 such that  $x^\infty(0) = \frac{\bar{x}}{2}$ .

**Lemma 5.13** *Assume that  $R_0 > 1$ . Let  $y_0 \in (0, 1]$  be given and let us denote by  $(x^\varepsilon, y^\varepsilon)$  the solution of (2.1) with initial data  $(0_C, y_0)$ . Then for each  $\varepsilon > 0$  one has*

$$t_\varepsilon := \sup \left\{ t \geq 0 : x^\varepsilon(t) = \frac{\bar{x}}{2} \right\} < \infty \text{ and } \lim_{\varepsilon \rightarrow 0} t_\varepsilon = \infty,$$

and the following convergence holds true

$$\lim_{\varepsilon \rightarrow 0} x^\varepsilon(t + t_\varepsilon) = x^\infty(t),$$

converges uniformly on any intervals of the form  $[-T, +\infty)$  with  $T \geq 0$ .

*Proof.* By using the same arguments as in the proof of Proposition 5.1 we obtain that there exists a family  $\{t_\varepsilon\}_{\varepsilon>0}$  such that for each  $\varepsilon > 0$ :

$$x^\varepsilon(t_\varepsilon) = \frac{\bar{x}}{2} \text{ and } \lim_{\varepsilon \rightarrow 0} t_\varepsilon = \infty. \quad (5.23)$$

and such that the family of function  $\hat{x}^\varepsilon(t) := x^\varepsilon(t + t_\varepsilon)$  converges locally uniformly to the unique heteroclinic orbit  $x^\infty$ . Now let  $T > 0$  be given. We claim that  $\hat{x}^\varepsilon$  converges uniformly to  $x^\infty$  on  $[-T, +\infty)$ . Indeed assume that the convergence is not uniform on  $[-T, +\infty)$ . Then there exists a sequence  $\{\varepsilon_n\}$  tending to 0 as  $n \rightarrow \infty$ ,  $\eta > 0$  and a sequence  $t_n \rightarrow +\infty$  as  $n \rightarrow +\infty$  such that

$$|\hat{x}^{\varepsilon_n}(t_n) - x^\infty(t_n)| > \eta, \quad \forall n \geq 0. \quad (5.24)$$

Consider now the sequence of map  $x^n(t) := \hat{x}^{\varepsilon_n}(t_n + t)$ . Then since  $\hat{x}^{\varepsilon_n}(0) = \frac{\bar{x}}{2}$ , Lemma 4.4 applies and provides that

$$\lim_{n \rightarrow +\infty} \hat{x}^{\varepsilon_n}(t + t_n) = \bar{x}, \text{ locally uniformly.}$$

Since  $x^\infty(t_n) \rightarrow \bar{x}$  as  $n \rightarrow \infty$  we reach a contradiction with (5.24). This completes the proof of the lemma and therefore completes the proof of Theorem (2.4). ■

## 6 Discussion

In this article we have investigated finite and infinite time singular limit for the following system of delay differential equations

$$\begin{cases} \frac{dx(t)}{dt} = -\mu x(t) + \alpha y(t)(1 - x(t)), \quad \forall t \geq 0, \\ \varepsilon \frac{dy(t)}{dt} = -\nu y(t) + \beta x(t - \tau)(1 - y(t)), \quad \forall t \geq 0, \\ y(0) = y_0 \in \mathbb{R}, \text{ and } x_0 = \varphi \in C([- \tau, 0], \mathbb{R}). \end{cases} \quad (6.1)$$

From a practical point of view, no information is available for the parameters of the second equation (i.e. HCW equation). The results of this paper show that we can replace  $y$  in first equation of system (6.1) by

$$y(t) = h(x(t - \tau)) = \frac{\beta x(t - \tau)}{\nu + \beta x(t - \tau)}.$$

Therefore the system (6.1) is reduced to a single equation

$$\frac{dx(t)}{dt} = -\mu x(t) + \alpha h(x(t - \tau))(1 - x(t)), \quad \forall t \geq 0.$$

This new model provide a good generally approximation of the first equation in system (6.1) as soon as  $\varepsilon$  is small enough. We prove that the finite time

convergence is always true. Nevertheless when the infection starts only with contaminated HCW, some difficulties arise for the long term comparison.

In terms of mathematical perspectives, many questions remain. One should first extend the presents results to the original age-structured models (1.2)-(1.3). Another class of questions is can we reconsider the systems from abstract point of view. Namely it would be interesting to regard systems (6.1) as non-densely defined Cauchy problem. By using (for example) the approach presented in Liu, Magal and Ruan [19], one can reformulated system (6.1) in the following form

$$\begin{cases} \frac{d}{dt} \begin{pmatrix} 0_{\mathbb{R}} \\ u \end{pmatrix} = A \begin{pmatrix} 0_{\mathbb{R}} \\ u \end{pmatrix} + F \left( \begin{pmatrix} 0_{\mathbb{R}} \\ u \end{pmatrix}, y \right) \\ \varepsilon \frac{dy}{dt} = -\nu y(t) + \beta u(t, -\tau) (1 - y(t)) \end{cases}$$

where  $A : D(A) \subset X \rightarrow X$  is a linear operator on the Banach space

$$X = \mathbb{R} \times C([- \tau, 0], \mathbb{R})$$

defined by

$$A \begin{pmatrix} 0_{\mathbb{R}} \\ \psi \end{pmatrix} = \begin{pmatrix} -\psi'(0) \\ \psi' \end{pmatrix} \text{ with } D(A) = \{0_{\mathbb{R}}\} \times C^1([- \tau, 0], \mathbb{R})$$

and  $F : \overline{D(A)} \rightarrow X$  is the map defined by

$$F \left( \begin{pmatrix} 0_{\mathbb{R}} \\ \varphi \end{pmatrix}, y \right) = \begin{pmatrix} -\mu\varphi(0) + \alpha y (1 - \varphi(0)) \\ 0_C \end{pmatrix}.$$

According to our best knowledge, very few results are available in the literature for infinite dimensional singular limit. Some results are obtained for linear diffusion operators (see Bates Lu and Zeng [7] and reference therein), but for hyperbolic operators no general theory has been developed.

## References

- [1] P. Ankomah and B. R. Levin, Two-drug antimicrobial chemotherapy: A mathematical model and experiments with *Mycobacterium marinum*. *Plos Pathogens* **(8)1** (2012) e1002487
- [2] W. Arendt, C. J. K. Batty, M. Hieber and F. Neubrander, *Vector-Valued Laplace Transforms and Cauchy Problems*, Birkhauser, Basel, (2001).
- [3] O. Arino, M. Hbid, E. Ait Dads (Eds.), *Delay Differential Equations with Application*, in: NATO Sci. Ser., vol. 205, Springer-Verlag, Berlin, (2006).
- [4] O. Arino, E. Sanchez, R. Bravo de la Parra, P. Auger, A singular perturbation in an age-structured population model, *SIAM J. Appl. Math.*, **60** (1999), 408-436.

- [5] Z. Artstein and M. Slemrod, On Singularly Perturbed Retarded Functional Differential Equations, *Journal of Differential Equations* **171** (2001), 88-109.
- [6] P. Auger, R. Bravo de la Parra, J.-C. Poggiale, E. Sanchez and T. Nguyen-Huu, Aggregation of variables and applications to population dynamics. In: Magal, P., Ruan, S. (Eds.), *Structured Population Models in Biology and Epidemiology Series: Lecture Notes in Mathematics, Subseries: Mathematical Biosciences Subseries*, vol. 1936, (2008) 345 p.
- [7] P.W. Bates, K. Lu, C. Zeng, Approximately invariant manifolds and global dynamics of spike states, *Invent. Math.* **174** (2008), 355-433.
- [8] J. Carr and A. Chmaj, Uniqueness of travelling waves for nonlocal monostable equations. *Proc. Amer. Math. Soc.*, **132** (2004), 2433-2439.
- [9] F. Chamchod and S. Ruan, Modeling the Spread of Methicillin-Resistant *Staphylococcus aureus* in Nursing Homes for Elderly. *PLoS ONE* 7(1): (2012) e29757. doi:10.1371/journal.pone.0029757
- [10] E. D'Agata, P. Magal, S. Ruan and G. F. Webb, Asymptotic behavior in nosocomial epidemic models with antibiotic resistance, *Differential and Integral Equations* **19** (2006), 573-600.
- [11] E.M.C. D'Agata, P. Magal, D. Olivier, S. Ruan and G.F. Webb, Modeling Antibiotic Resistance in Hospitals: The Impact of Minimizing Treatment Duration, *Journal of Theoretical Biology* **249**(2007), 487-499.
- [12] E. M.C. D'Agata, M. Dupont-Rouzeyrol, P. Magal, D. Olivier, S. Ruan, The Impact of Different Antibiotic Regimens on the Emergence of Antimicrobial-Resistant Bacteria. *PLoS ONE* **3(12)** (2008), 1-9.
- [13] E. M. C. D'Agata, M. A. Horn, S. Ruan, G. F. Webb, and J. R. Wares, A comprehensive transmission model of multidrug-resistant organisms in the hospital setting, *PLoS ONE* Vol. 7(2): (2012) e30170.doi:10.1371/journal.pone.0030170.
- [14] O. Diekmann, S.A. van Gils, S.M. Verduyn Lunel, H.-O. Walther, *Delay Equations, Function-, Complex-, and Nonlinear Analysis*, Springer-Verlag, New York, 1995.
- [15] A. Ducrot, P. Magal and O. Seydi, Nonlinear boundary conditions derived by singular perturbation in age structured population dynamics model, *Journal of Applied Analysis and Computation* **1** (2011), 373-395.
- [16] A. Friedman, N. Ziyadi and K. Boushaba, A model of drug resistance with infection by healthcare workers, *Math. Biosciences and Engineering*, **7** (2010), 779-792.

- [17] J.K. Hale and S.M. Verduyn Lunel, *Introduction to Functional Differential Equations*, Springer-Verlag, New York, 1993.
- [18] G. Hek, Geometric singular perturbation theory in biological practice. *J. Math. Biol.* **60** (2010), 347-386.
- [19] Z. Liu, P. Magal and S. Ruan, Projectors on the generalized eigenspaces for functional differential equations using integrated semigroups, *Journal of Differential Equations* **244** (2008), 1784-1809.
- [20] P. Magal and C.C. McCluskey, Two group infection age model: an application to nosocomial infection, *SIAM J. Appl. Math.*, **73(2)** (2013), 1058-1095.
- [21] L. T. Magalhães, Convergence and boundary layers in singularly perturbed linear functional-differential equations. *J. Differential Equations* **54** (1984), 295-309.
- [22] L.T. Magalhães, Persistence and smoothness of hyperbolic invariant manifolds for functional-differential equations. *SIAM J. Math. Anal.* **18** (1987), 670-693.
- [23] A. R. Ortiz, H. T. Banks, C. Castillo-Chavez, G. Chowell and X. Wang, A deterministic methodology for estimation of parameters in dynamic Markov chain models, *J. Biological Systems*, **19** (2011), 71-100.
- [24] H.L. Smith, *Monotone Dynamical Systems, an Introduction to the Theory of Competitive and Cooperative Systems*, American Mathematical Society, Mathematical Surveys and Monographs (1995).
- [25] H.L. Smith, *An Introduction to Delay Differential equations with Applications to the Life Sciences*, Texts in Applied Math. Vol 57, Springer, (2010).
- [26] G.F. Webb, E.M.C. D'Agata, P. Magal and S. Ruan, A model of antibiotic-resistant bacterial epidemics in hospitals, *PNAS* **102** (2005), 13343-13348.
- [27] D.V. Widder, *The Laplace Transform*. Mathematical Series, 6, Princeton university press, Princeton, NJ, (1941).
- [28] Z.-X. Yu and M. Mei, Asymptotics and Uniqueness of Travelling Waves for Non-Monotone Delayed Systems on 2D Lattices, *Canadian Mathematical Bulletin*, doi:10.4153/CMB-2011-180-4, (2011).